

2OD Series

2OD-50DXC



Why Choose the 2OD Series?

When a single bay solution just isn't sufficient, the 2OD series enclosures are ideal. Constructed of our own rugged Alumiflex®, it is noticeably lighter than steel yet strong enough to rack the heaviest equipment. The 2OD-50DXC includes a number of standard features, such as an adjustable racking system with a versatile rail strut system (R-Strut), a 3-point locking system for security, a reversible rack system for 19" and 23" applications, lifting hooks for easy maneuvering into place, wind locks to secure doors safely when they are open, and our patented Alumishield® solar cap for managing heat loads. Furthermore, DDB offers an array of customizable choices, which include climate control (HVAC), electrical load panels, and cable entry solutions. These possibilities combine to produce an enclosure that can be customized to meet the specific needs that your site and clients may require. The 2OD undoubtedly closes the gap between single-bay enclosures and larger building "hut" solutions, giving you the flexibility to meet any need in the field without the required stamps or inspections that traditional "huts" do. With an industry-leading 15-year warranty on every enclosure, DDB provides cutting-edge design, competitive pricing, benchmark lead times, and guaranteed delivery. Whether you require a custom enclosure or something from our substantial stock, our professional staff is here to help you today.



Application Types

- Telecommunications
- Wireless/Broadband
- Fiber Optics
- Back Haul
- Public Safety
- Utility
- Base Station
- Military
- Trailer-Based Communications
- Wi-Fi
- LTEE/4G/5G



Environmental & Safety Ratings:

- ✓ NEMA 3R (shown above)
- ✓ NEMA 4 and 4X configurable (not shown)

2301 S. HWY 77 Pauls Valley, OK 73075
T: (405)-665-2876

sales@ddbunlimited.com www.ddbunlimited.com

Features

- 15 Year Warranty
- 0.125" Aluminum Construction
- 3 Point Lock System
- Heavy Duty Out-Door Construction
- Front and Rear Access
- Standard Lifting Hooks
- Stainless Steel External Hardware/Hinge
- Cream Powder-Coat, Standard
- Quick Shipping

Weight and Dimensions

Approximate Exterior Enclosure Dimensions:

51"H x 65"W x 30"D

Shipping Dimensions:

52"L x 84"W x 60"H - Palletized

Approximate Shipping Weight:

425 lbs.

20D Series

20D-50DXC



Features

1. Alumishield
2. 19" and 23" Adjustable Racking Rails
3. 3 Point Locking System
4. Stainless Steel Door Hinge
5. Powder-Coat Cream
6. Wind Locks
7. Rear Door Access
8. Reusable Filters
9. Heavy Duty 0.160" Doors

Scan this code for
Climate Control



Scan this code for
Accessories



2301 S. HWY 77 Pauls Valley, OK 73075

T: (405)-665-2876

sales@ddbunlimited.com www.ddbunlimited.com

REVISIONS		
REV.	DESCRIPTION	DATE
A	Initial Release per DR-00963	5/28/2014
B	UPDATED TO 2017 WEBSITE FORMAT	8/11/2017
C	UPDATED NEW FORMAT	11/18/2020

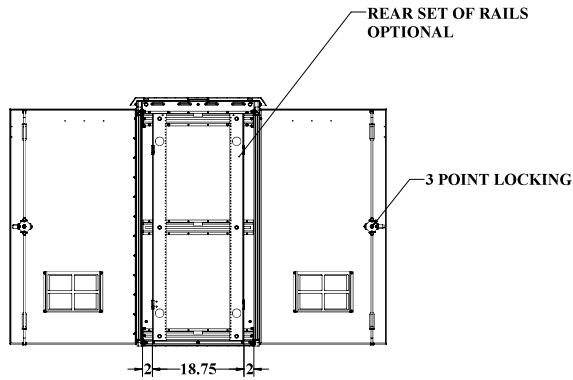
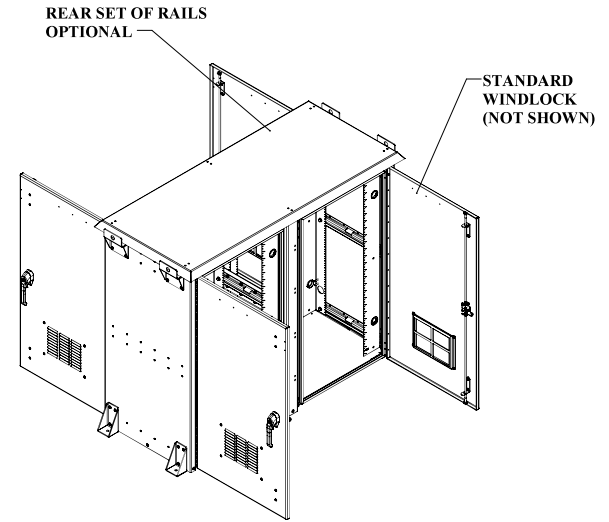
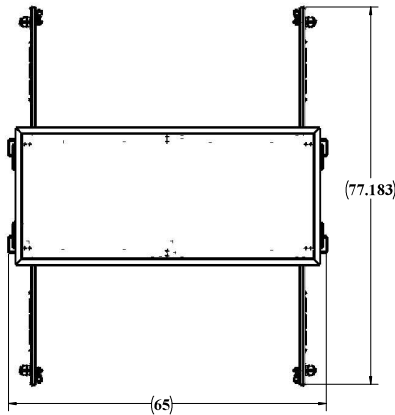

SECTION A-A
SCALE 1:12

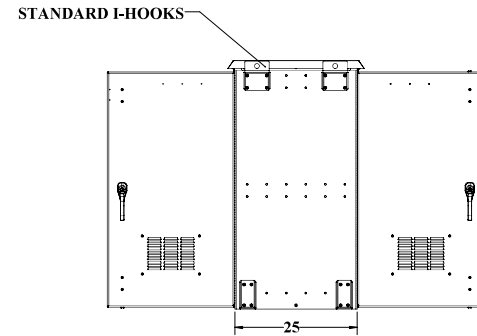
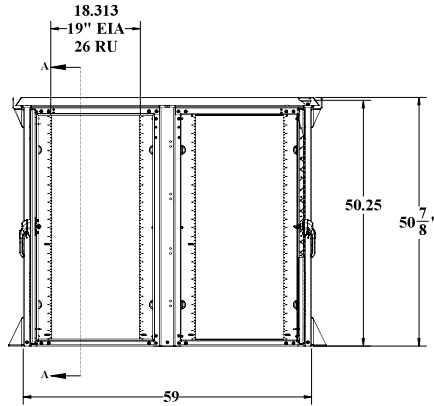

UNLESS OTHERWISE SPECIFIED:			
DIMENSIONS ARE IN INCHES			
WELDING	AS PER	AWG	
DUCTILE CAST IRON	AS PER		
STEEL	AS PER		
STAINLESS STEEL	AS PER		
ALL FINISHES	AS PER		
MATERIALS SPECIFIED BY ASTM BIPM			
PAINTE: 60000-1080-0000-0000-0000-0000-0000-0000			
DDB Unlimited Inc.		200A-50DX	
DWG. WEB. 30D. 50. DX			
REV	Code Code:	DWG. NO.:	REV
D	38515	00963	C
SCALE: 1:8		WEIGHT: 304 lbs.	SHEET 1 OF 3

UNCLASSIFIED PUBLIC

WEB DRAWING (NOT FOR FABRICATION)

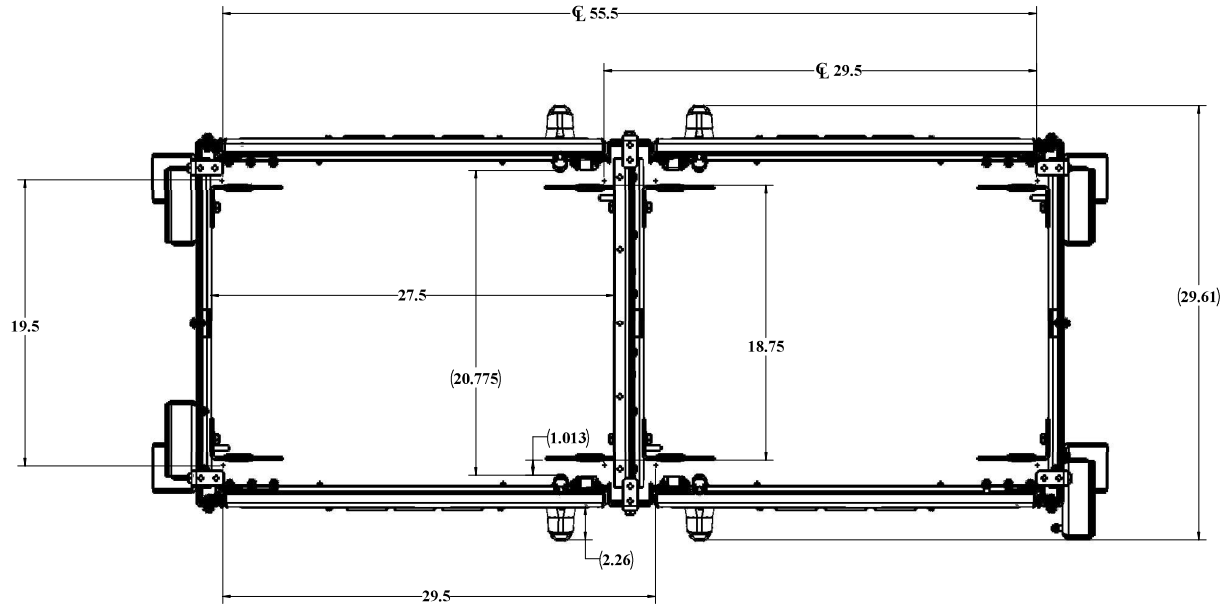

TOP VIEW SOLAR SHIELD AND CEILING NOT SHOWN

WEB DRAWING (NOT FOR FABRICATION)

DESIGN OTHERWISE SPECIFIED:		DDP Unlimited Inc.	
DIMENSIONS ARE IN MILLIMETERS		20D-50Dx (CLOSED)	
MATERIAL: 2019 ALUMINUM		DWG. NO.: 00943	
FINISH: ANODIZED		REV: D	REV: C
SCALE: 1:8		WEIGHT: 304 lbs.	SHEET 2 OF 3

UNCLASSIFIED PUBLIC
 THE INFORMATION CONTAINED IN THIS DRAWING IS THE SOLE PROPERTY OF DDB Unlimited, INC. ANY REPRODUCTION IN PART OR AS A WHOLE WITHOUT THE WRITTEN PERMISSION OF DDB Unlimited, INC. IS PROHIBITED.

File Location: [DDB] EPDM Vault
 C:\DDB\DR Requests\Customer\20D WEB.DWG\20D Family WEB\DR-00943 (20D-50Dx) WEB

DDB FORM 7-1-2 REV A 08/02/17

WEB DRAWING (NOT FOR FABRICATION)

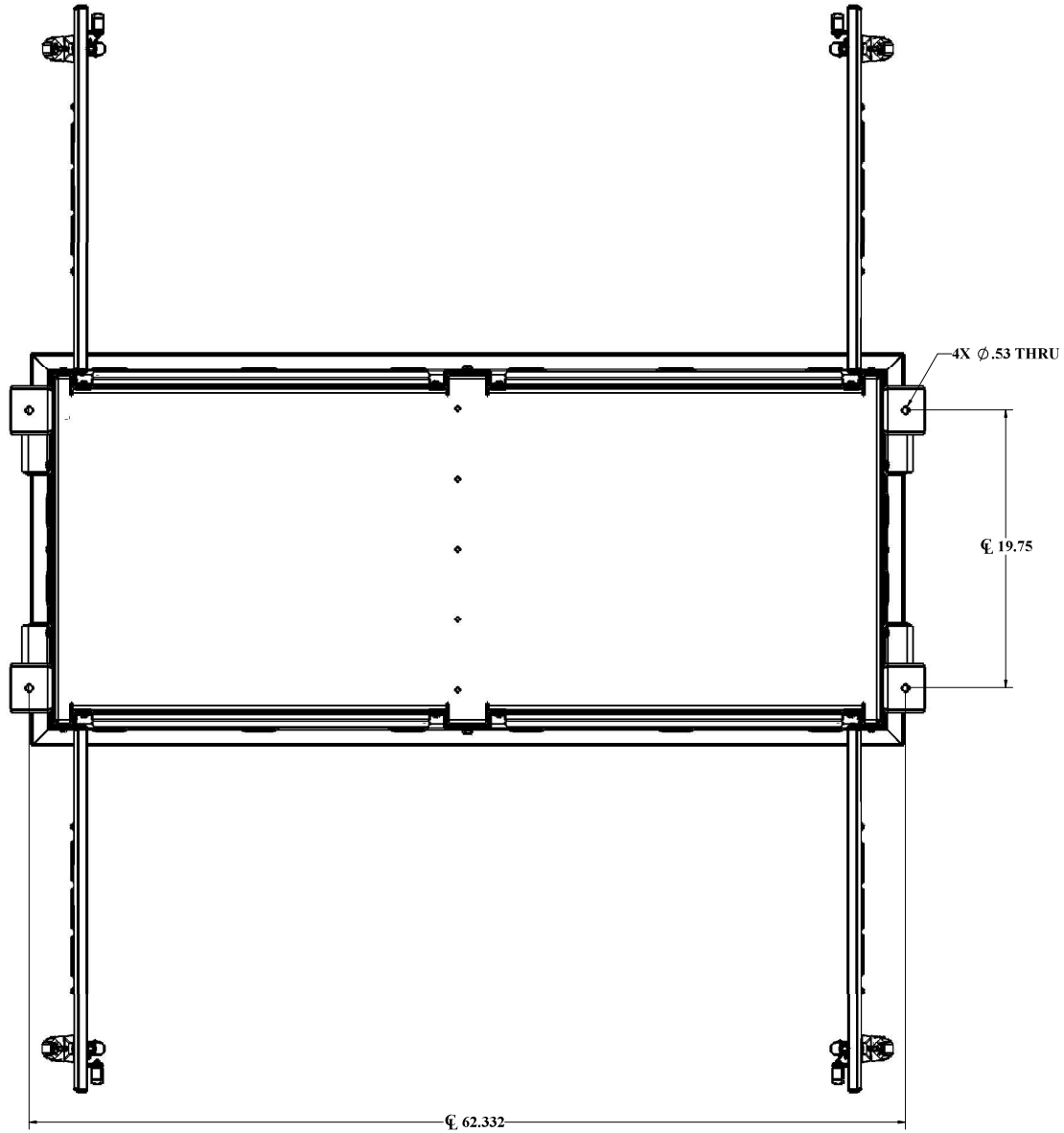

BOTTOM VIEW MOUNTING HOLES

WEB DRAWING (NOT FOR FABRICATION)

UNLESS OTHERWISE SPECIFIED:			
2024-2025			
DDB Unlimited Inc.			
DWG, WEB, 30D, 3R, DX			
REV	Code Code:	DWG. NO.:	REV
D	28515	00963	C
MATERIAL: 304/316 SS BUNGE		SCALE: 1:8	
PAINT: BUNGE PAINT 304/316 SS BUNGE		WEIGHT: 223 lbs	
DO NOT SCALE DRAWING			
2		SHEET 2 OF 3	

UNCLASSIFIED PUBLIC
 THE INFORMATION CONTAINED IN THIS DRAWING IS THE SOLE PROPERTY OF DDB Unlimited, INC. ANY
 REPRODUCTION IN PART OR AS A WHOLE WITHOUT THE WRITTEN PERMISSION OF DDB Unlimited, INC. IS PROHIBITED.

File Location: [DDB] EPDM Vault:
 C:\DDB\DR Requests\Customer\30D WEB DWG\30D Family WEB\DR-00963 (2024-2025) WEB

DDB FORM 7.1-2 REV A 08/02/17