

WOD Series-UL Listed

WOD-16DDC-UL50



Why Choose the WOD Series-UL Listed?

The WOD-16DDC-UL50 enclosure is the pinnacle of enclosures. With a fully welded chassis, heavy duty vulcanized gasketing and years of design and engineering behind it, you will find this will meet the most stringent requirements of the UL-50E Type 4 listing. Fully tested by a third party Nationally Recognized Testing Laboratory and listed to the UL-50E standard, you can trust that the WOD UL series will pass any test or inspection it faces. Designed with public safety requirements in mind, these units can be placed in mission critical locations where communication or sensitive gear needs to be protected regardless of the situation. As with the standard WOD series, the WOD-UL series comes with standard 3 point locking, front and rear access with integrated wind locks, top mounted solar shield, adjustable R-strut racking, reversible 19" or 23" EIA racking, Alumiflex construction and our unmatched 15-year warranty. Moreover, there is an extensive list of optional accessories including HVAC units, electrical panels, and cable entry solutions to name a few. No matter the application, DDB provides cutting-edge design, competitive pricing, benchmark lead times, and guaranteed delivery. Whether you require a custom enclosure or something from our substantial stock, our professional staff is here to help you today.

Application Types

- Telecommunications
- Wireless/Broadband
- Fiber Optics
- Back Haul
- Public Safety
- DAS
- Utility
- Base Station
- Military
- Trailer-Based Communications
- Wi-Fi
- LTEE/4G/5G

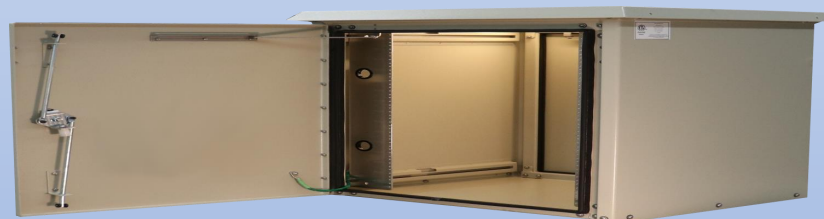

Environmental & Safety Ratings:

- ✓ UL Type 4 (shown above)



Features

- 15 Year Warranty
- 0.125" Aluminum Construction
- 3 Point Lock System
- Heavy Duty Out-Door Construction
- Front and Rear Access
- Stainless Steel External Hardware/Hinge
- Cream Powder-Coat, Standard
- Wind Locks
- Quick Shipping

Weight and Dimensions

Approximate Exterior Enclosure Dimensions:

18"H x 33"W x 39"D

Shipping Dimensions:

42"L x 42"W x 26"H- Palletized

Approximate Shipping Weight:

130 lbs.

WOD Series-UL Listed

WOD-16DDC-UL50

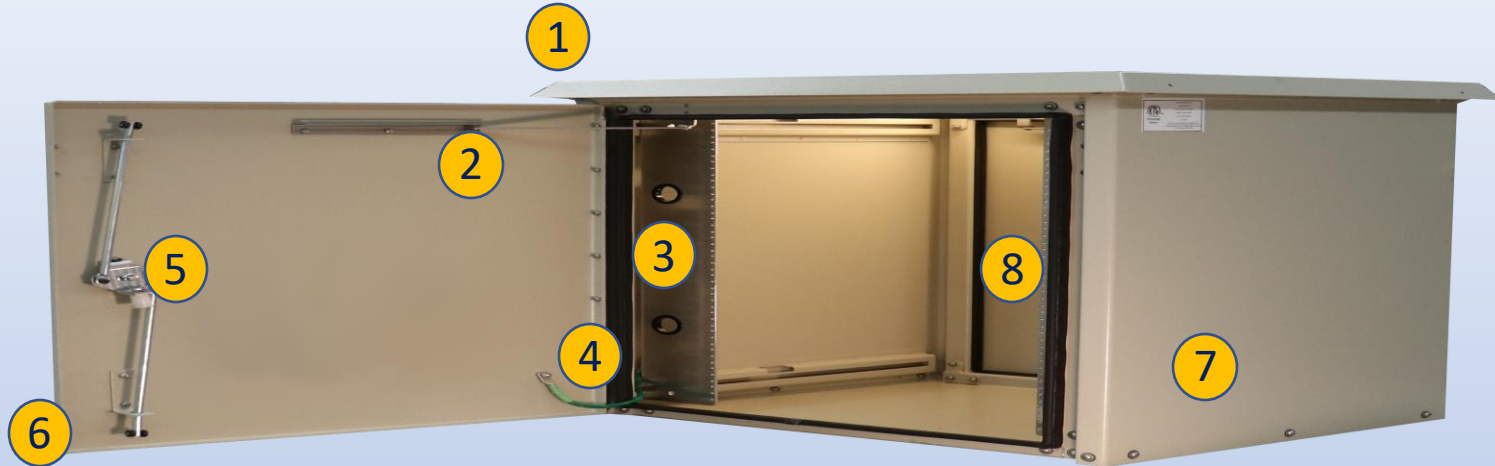

Features

1. Alumishield
2. Wind Locks
3. 19" and 23" Adjustable Racking Rails
4. Stainless Steel Door Hinge
5. 3 Point Locking System
6. Heavy Duty 0.160" Doors
7. Powder-Coat Cream
8. Rear Door Access

2301 S. HWY 77 Pauls Valley, OK 73075

T: (405)-665-2876

sales@ddbunlimited.com www.ddbunlimited.com

Scan this code for
Climate Control



Scan this code for
Accessories



REVISIONS		
REV.	DESCRIPTION	DATE
A	MADE DRAWING PER DR-02051	6/26/2019

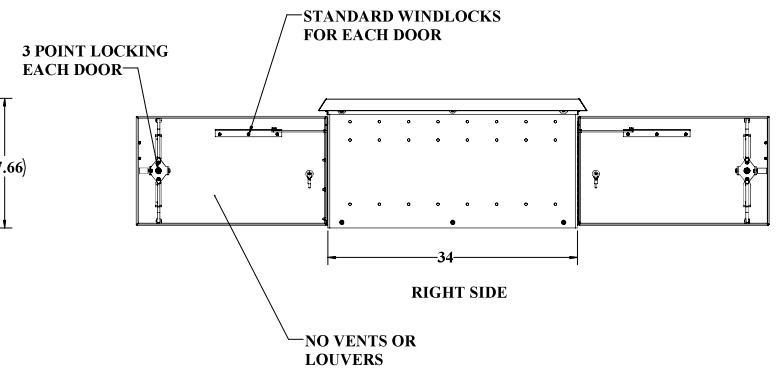
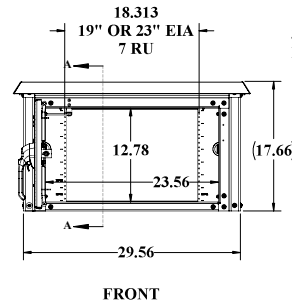
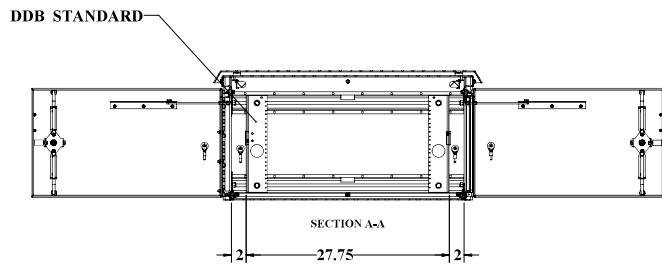
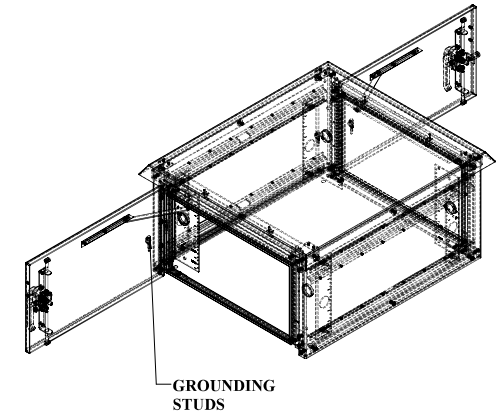
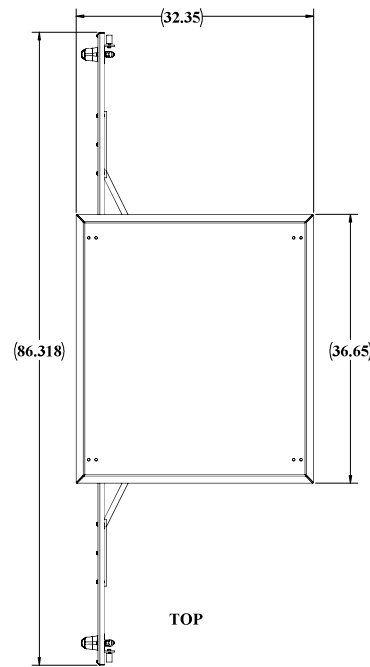

WELDED ENCLOSURE

UNCLASSIFIED PUBLIC

UNLESS OTHERWISE SPECIFIED:			
DIMENSIONS ARE IN INCHES			
WCD-1455-UL50E			
N.O.D. 14" H. DD V.1.5W/010-1455-UL50E			
REV	Code Code:	DWG. NO.:	REV
D	28515	02051	A
SCALE: 1:8		WEIGHT 99 lbs.	SHEET 1 OF 3

WEB DRAWING (NOT FOR FABRICATION)

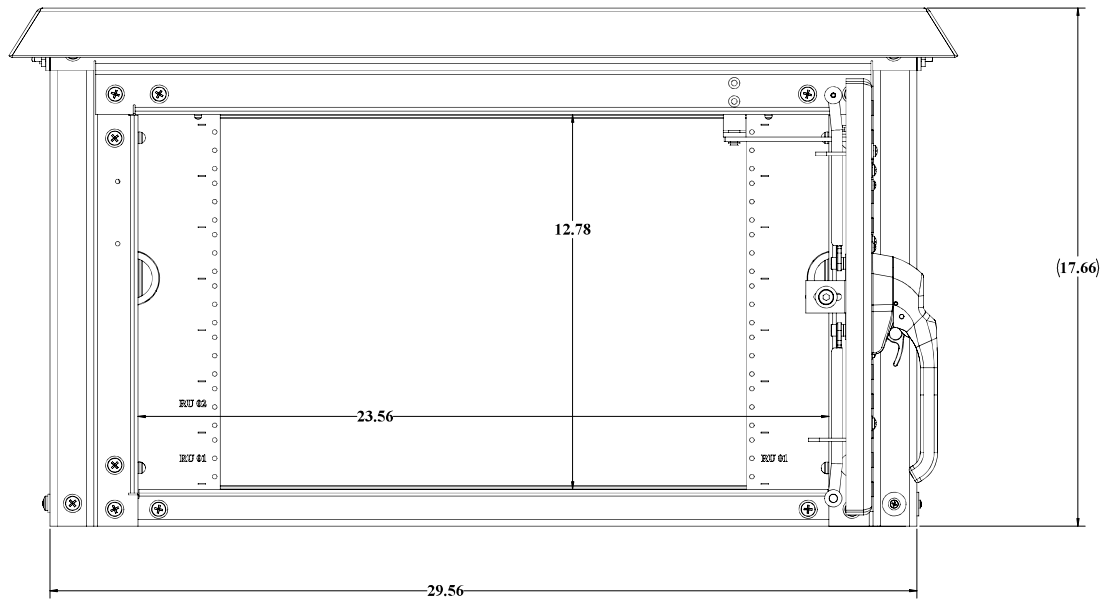

BACK VIEW
GASKET NOT SHOWN

WEB DRAWING (NOT FOR FABRICATION)

UNLESS OTHERWISE SPECIFIED:			
DIMENSIONS ARE IN INCHES			
WQD-1400-UL50E			
DDB Unlimited Inc.			
N.O.D. 14" H, 10" D, 1.5" W QD-1400-UL50E			
SIZE	Case Code:	DWG. NO.:	REV.
D	28515	02051	A
MATERIAL SPECIFICATION: ALUMINUM			
PAINT: POWDER COAT, BLACK			
DO NOT SCALE DRAWING			
SCALE: 1:8		WEIGHT: 99 lbs.	SHEET 2 OF 3

UNCLASSIFIED PUBLIC