

# WOD Series

## WOD-78DXC



## Why Choose the WOD Series?

The WOD series of enclosures are the ultimate choice for your outdoor racking requirements. Being made of our own rugged Alumiflex®, you'll find it noticeably lighter than steel, yet strong enough to rack even the heaviest equipment. When choosing the WOD series, you have handpicked the highest value in American construction. The WOD-78DXC includes the standard features you have come to expect with DDB, incorporating the versatile strut system for adjustable racking, the security of a 3-point locking system and our patented Alumishield® solar cap to manage heat loads. For those who need more than just our standard enclosure, DDB can also make a truly customized solution with our many available options including HVAC, providing a climate-controlled environment for any electronic equipment, electrical load panels and cable entry solutions to name a few. All of this comes together to create an enclosure able to meet all of the unique needs your customers have been seeking. DDB offers a state-of-the-art design, a competitive price, benchmark lead times and a guaranteed delivery, all backed up with an industry leading 15-year warranty on every enclosure. Put DDB's substantial stock to work for you today. Contact our professional staff to assist you with your made-to-order solution.

## Application Types

- Telecommunications
- Wireless/Broadband
  - Fiber Optics
  - Back Haul
- Base Station
- Small Cell/DAS
  - Utility
  - Military
- Trailer-Based Communications
  - Wi-Fi
- Flexible and Scalable



## Environmental & Safety Ratings:

- ✓ NEMA 3R, 4 or 4X
- ✓ ETL Certified to UL standard 60950-1/CSA 22.2C



## Features

- 15 Year Warranty
- 0.125" Aluminum Construction
- 3 Point Lock System
- Heavy Duty Out-Door Construction
- Front and Rear Access
- Standard Lifting Hooks
- Stainless Steel External Hardware/Hinge
- Cream Powder-Coat, Standard
- Quick Shipping

## Weight and Dimensions

Approximate Exterior Enclosure Dimensions:

79"H x 33"W x 30"D

Shipping Dimensions:

84"H x 32"W x 42"D- Palletized

Approximate Shipping Weight:

250lbs.

2301 S. HWY 77 Pauls Valley, OK 73075

T: (405)-665-2876

[sales@ddbunlimited.com](mailto:sales@ddbunlimited.com) [www.ddbunlimited.com](http://www.ddbunlimited.com)

# WOD Series

## WOD-78DXC



### Features

1. Alumishield
2. Wind Locks
3. 19" and 23" Adjustable Racking Rails
4. Rear Door Access
5. 3 Point Locking System
6. Stainless Steel Door Hinge
7. Reusable Vent Filters
8. Heavy Duty 0.160" Doors
9. Powder-Coat Cream

2301 S. HWY 77 Pauls Valley, OK 73075

T: (405)-665-2876

[sales@ddbunlimited.com](mailto:sales@ddbunlimited.com) [www.ddbunlimited.com](http://www.ddbunlimited.com)

Scan this code for  
Climate Control



Scan this code for  
Accessories



REVISIONS		
REV.	DESCRIPTION	DATE
A	Initial Web Drawing per DR-00134	6/10/2013
B	revise to incorporate new components and new drawing template pdr DR-00933	5/15/2014
C	UPDATED TO 2019 FORMAT	5/6/2019
D	UPDATED DRAWING WITH DOOR RODS WITH ROLLERS PER DR-02277	6/16/2020

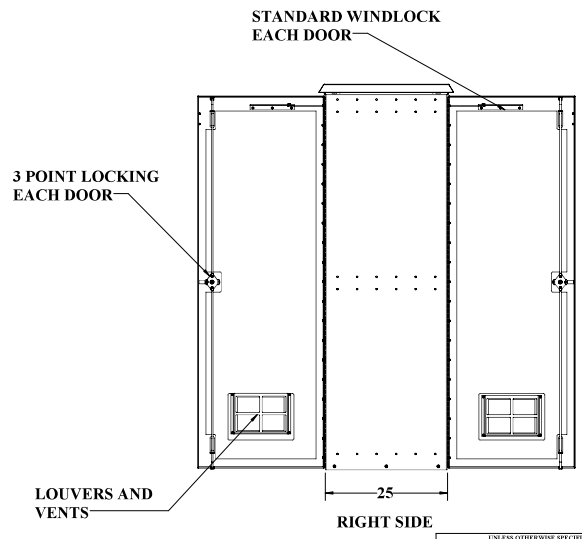
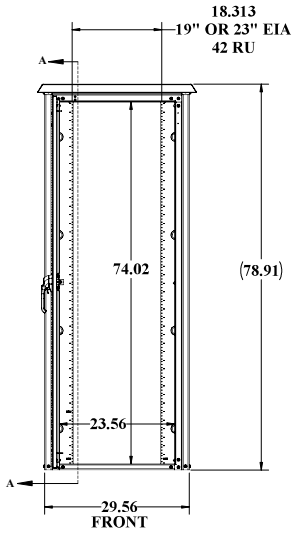
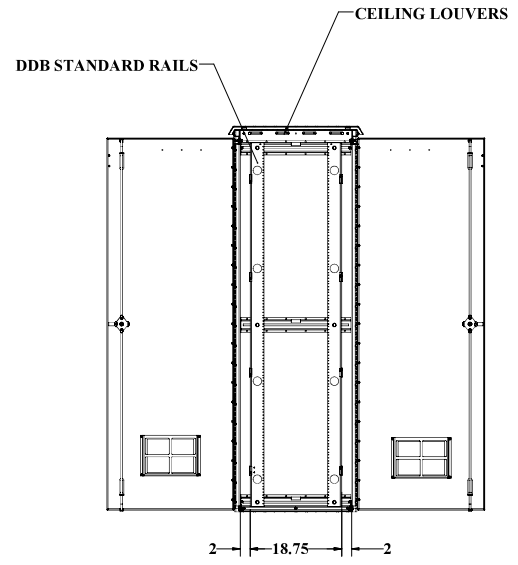
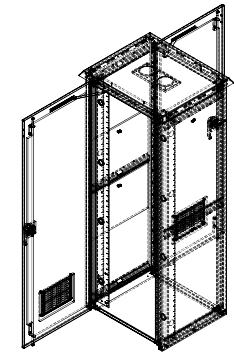
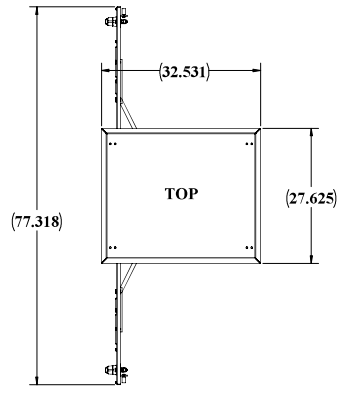

UNLESS OTHERWISE SPECIFIED:			
DIMENSIONS ARE IN INCHES		WOB-78DX (WEB)	
EXCEPT AS NOTED	1/8"	WOB-787H, 18XWOL-78DX (WEB)	
EXCEPT AS NOTED	1/16"	REV	
EXCEPT AS NOTED	1/32"	CODE	00724
EXCEPT AS NOTED	3/16"	DWG. NO.	
EXCEPT AS NOTED	1/2"	REV	
EXCEPT AS NOTED	5/8"	D	
EXCEPT AS NOTED	3/4"	D	
EXCEPT AS NOTED	1"	SCALE	1:12
EXCEPT AS NOTED	1 1/4"	WEIGHT	218 Lbs.
EXCEPT AS NOTED	1 1/2"	SHEET	1 OF 3

UNCLASSIFIED PUBLIC

DDB FORM: 7.1.2 REV: A 08/02/17



