



An ISO 9001
Certified company

SOD Series- UL Listed

SOD-302420-UL50

Made in America



Believing in American
Craftsmanship



Why Choose the SOD Series-UL Listed?

The SOD-302420-UL50 enclosure stands as a top choice for outdoor equipment racking, offering unparalleled versatility. Constructed with our Alumiflex® material, it is notably lighter than steel yet strong enough to rack the heaviest equipment with ease. The SOD-UL50 series boasts effortless installation and provides pad, pole, and wall mounting options for endless placement possibilities. As shown in Type 4 configuration (w/o vents), the SOD-UL series is also available in a Type 3R configuration (with vents). With standard features like a 3-point pad locking system, built in solar cap to manage heat loads, door grounding straps, and UL-listed gasketing, the SOD-UL's value is unmatched. Adding to the flexibility, the SOD-UL series is configurable to be used for in indoor and outdoor applications and has an extensive list of available options, including climate controls, electrical and cable entry solutions. All of this comes with the industry's best lead times, unmatched warranty and competitive pricing. As expected, the DDB SOD-UL50 series sets the mark as a design leader that is versatile and scalable to meet a wide array of situations. Contact our knowledgeable sales team for more information.



Features

15 Year Warranty

0.125" Aluminum Construction

3-Point Pad Locking System

Heavy Duty Construction with Front Door Access

Standard Lifting Hooks

Stainless Steel External Hardware/Hinge

Cream Powder- Coat, Standard

Quick Shipping

Weight and Dimensions

Approximate Exterior Enclosure Dimensions:

32"H x 24"W x 24"D

Shipping Dimensions:

42"L x 32"W x 40"H- Palletized

Approximate Shipping Weight:

100 lbs.

Application Types

Provides A Secure Climate Controlled
Environment for any Electronic Equipment

Telecommunications

Wireless/Broadband

DAS/BDA

Fiber Optics

Back Haul

Base Station

Small Cell

Utility-Traffic

Trailer-Based Communications

Wi-Fi

Flexible and Scalable



Environmental & Safety Ratings:

✓ UL Listed

✓ Type 4 shown (w/o vents)

✓ Type 3R available (with vents)

2301 S. HWY 77 Pauls Valley, OK 73075

T: (405)-665-2876

sales@ddbunlimited.com www.ddbunlimited.com

SOD Series- UL Listed

SOD-302420-UL50



Features

1. Solar Cap
2. 19" Racking Rails
3. Stainless Steel Door Hinge
4. Door Grounding Straps
5. Padlocking Handles
6. 0.125" Aluminum Construction
7. Powder-Coat Cream

Scan this code for
Accessories



2301 S. HWY 77 Pauls Valley, OK 73075

T: (405)-665-2876

sales@ddbunlimited.com www.ddbunlimited.com

REVISIONS		
REV.	DESCRIPTION	DATE
A	CREATED WEBSITE DRAWING PER DR-02037	6/6/2019
B	UPDATED SHEET FORMAT PER NEWER CHANGED SEVERAL DECIMAL DIMENSIONS TO COMMON FRACTIONS.	8/14/2024

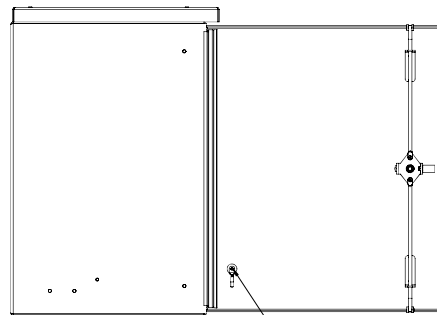
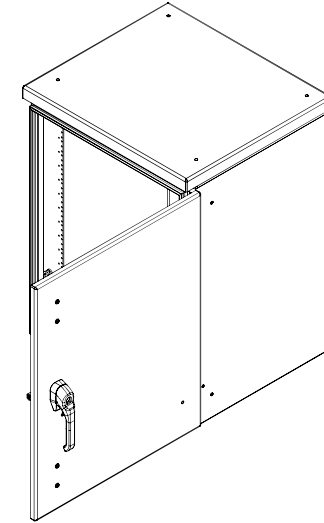
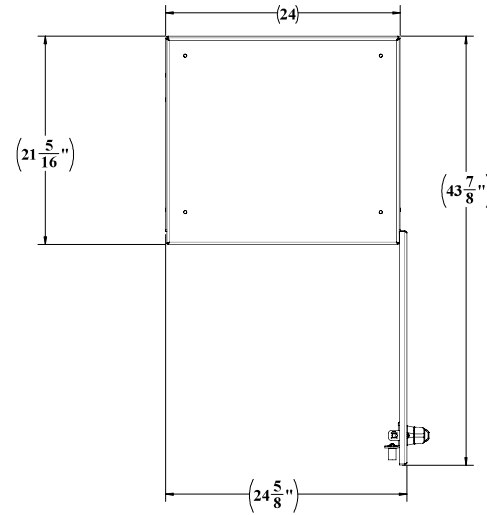

GROUNDING STUD & PAINT FREE AREA.

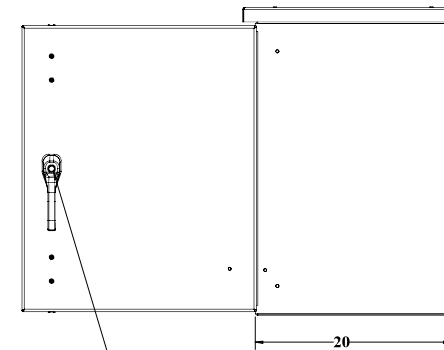
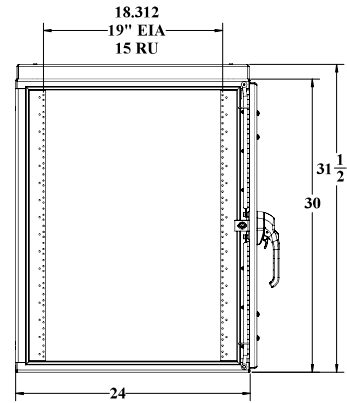

UNLESS OTHERWISE SPECIFIED:		DDB Unlimited Inc.	
DIMENSIONS ARE IN INCHES		SOD-302420-1150	
FINISH	1" 300	SHEET	8
DRILLING	3000	DATE	02037
DRILLING	3000	SCALE	1:8
DRILLING	3000	WEIGHT	94 lbs.
DRILLING	3000	SHEET 1 OF 2	

UNCLASSIFIED PUBLIC

DDB FORM 7.1-2 REV. A (08/02/17)

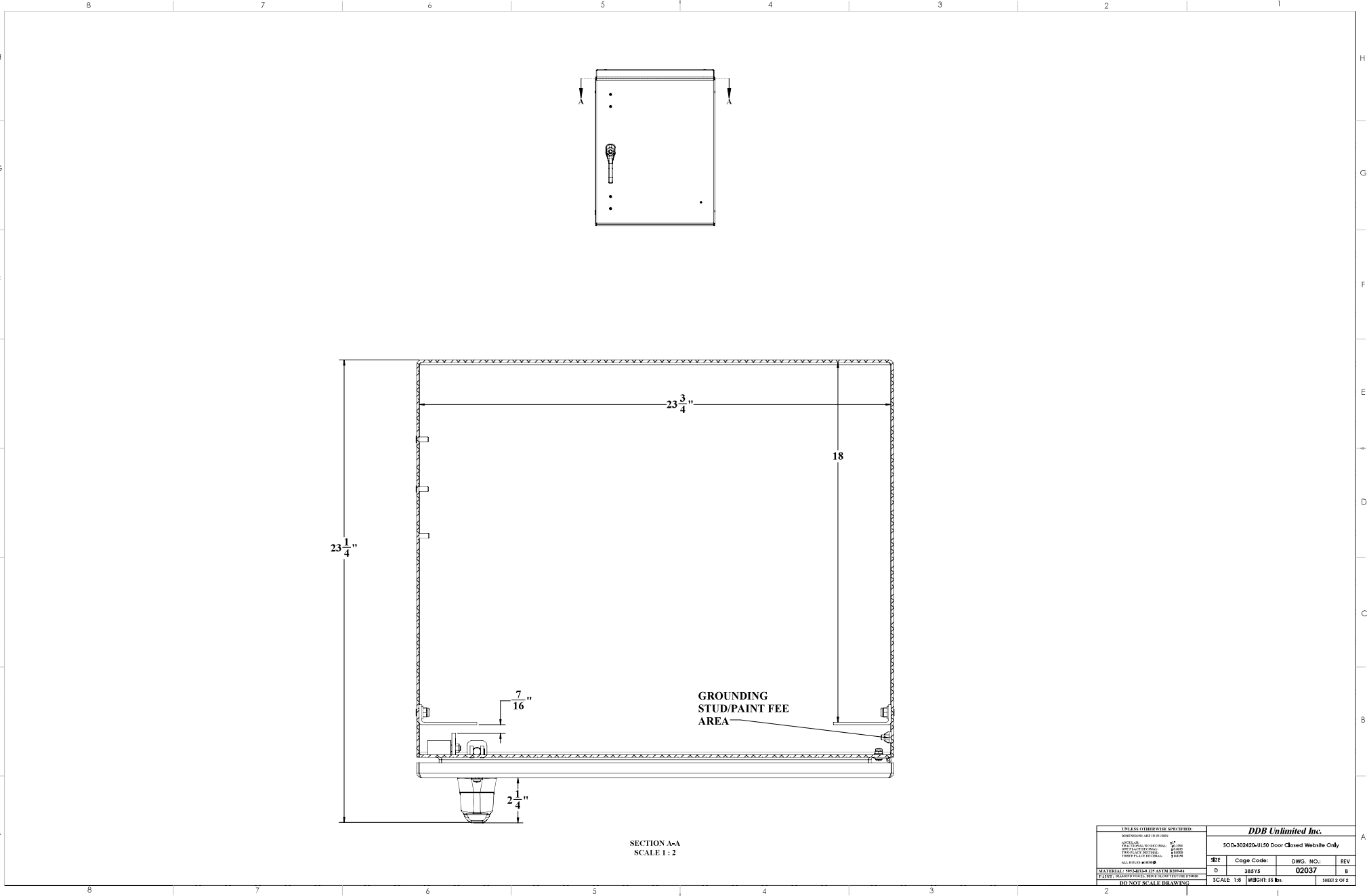

SECTION A-A
SCALE 1 : 2

UNCLASSIFIED PUBLIC

<small>UNLESS OTHERWISE SPECIFIED:</small> <small>FINISHES ARE PER DDB</small> <small>WARRANTY: 1 YEAR</small> <small>INSTALLATION: SEE INSTRUCTIONS</small> <small>DOOR: 1 3/4" x 2 1/4" x 1/2"</small> <small>HANDLE: 1 1/2" x 1/2" x 1/2"</small> <small>KEY: 1 1/2" x 1/2" x 1/2"</small> <small>ALL DIMENSIONS ARE IN INCHES</small>				DDB Unlimited Inc. SOD-302420-UI.50 Door Closed Website Only			
REV	Code Code:	DWG. NO.:	REV				
D	28515	02037	8				
<small>MATERIALS SPECIFIED BY ALTA BROWN</small> <small>PAINT: BROWN/BLACK - BUDGET/STANDARD</small>				SCALE: 1:8 WEIGHT 55 lbs. SHEET 2 OF 2			
<small>DO NOT SCALE DRAWING</small>							