

SBS Series

SBS-262210C



Why Choose the SBS Series?

The SBS-262210C outdoor enclosure is a top choice for indoor and outdoor needs. Constructed with our Alumiflex® material, it is notably lighter than steel yet strong enough to easily support the heaviest equipment. The SBS series has an updated design, including a deeper compartment for more equipment space and improved door compression to keep the weather out. The SBS series can be used as an electrical panel, battery storage, communication cabinet, and more. Standard features include an aluminum removable back-plate, 1/4 turn-key locks, and rugged aluminum construction. Configurable for indoor or outdoor applications the available accessories add the ability to customize to your specific application with various mounting bracket types, including climate controls, venting options, and electrical/cable entry solutions. Every SBS enclosure includes DDB's unmatched warranty, the industry's best lead times, and competitive pricing. As expected, the DDB SBS series sets the mark as a design leader that is versatile and scalable to meet a wide array of situations. Contact our knowledgeable sales team for more information.



Features

15 Year Warranty

.125" Aluminum Construction

Stainless Steel External Hardware/Hinge

Aluminum Removable Back-Plate

Cream Powder Coat, Standard

1/4 Turn-Key Locks

Flexible and Scalable

Quick Shipping

Weight and Dimensions

Approximate Exterior Enclosure

Dimensions:

26"H x 25"W x 10"D

Shipping Dimensions:

30"L x 30"W x 16"H- Boxed

Approximate Shipping Weight:

40lbs.

Application Types

Telecommunications

Wireless/Broadband

Fiber Optics

Small Cell/DAS

Public Safety

Utility

Military

Trailer-Based Communications

Wi-Fi

Video/Monitoring

Oil/Gas

Control Panels



Environmental & Safety Ratings:

✓ NEMA 4 (shown)

✓ 4X Available (not shown)

2301 S. HWY 77 Pauls Valley, OK 73075

T: (405)-665-2876

sales@ddbunlimited.com www.ddbunlimited.com



Features

1. Powder-Coat Cream
2. 0.125" Aluminum Construction
3. 1/4 Turn-Key Locks
4. Continuous Hinge
5. Removable Aluminum Backplate;
Optional Plywood Backplate

Scan this code for
Accessories



2301 S. HWY 77 Pauls Valley, OK 73075

T: (405)-665-2876

sales@ddbunlimited.com www.ddbunlimited.com

| REVISIONS | | |
|-----------|--------------------------------------------------------------------------------------------------------|----------|
| REV. | DESCRIPTION | DATE |
| A | SBS WEB DRAWING CREATED PER DR-2305 | 5/8/2020 |
| F | UPDATED TO REV F. DRAWINGS WERE NEVER UPDATED TO REV B, C, D, E. NO DRAWING REQUESTS WERE EVER ISSUED. | 5/9/2022 |

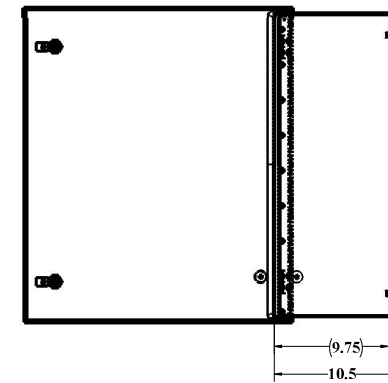
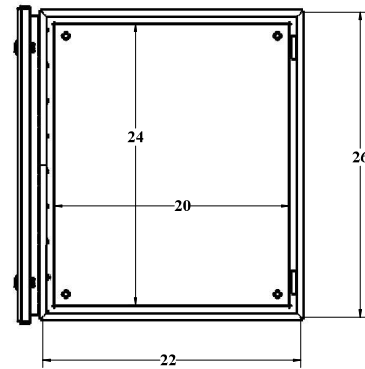
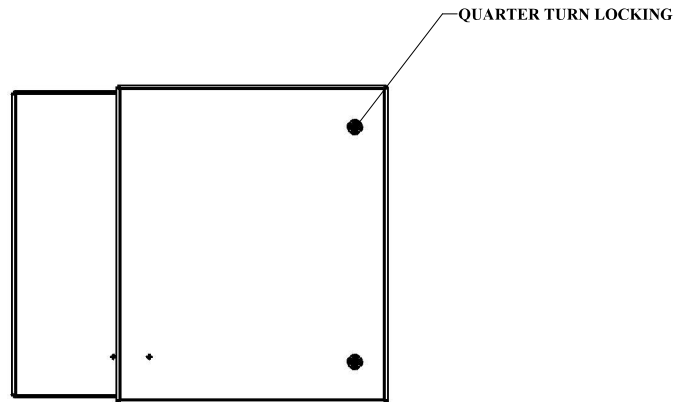
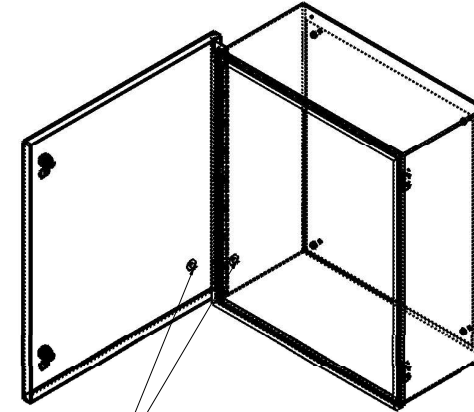
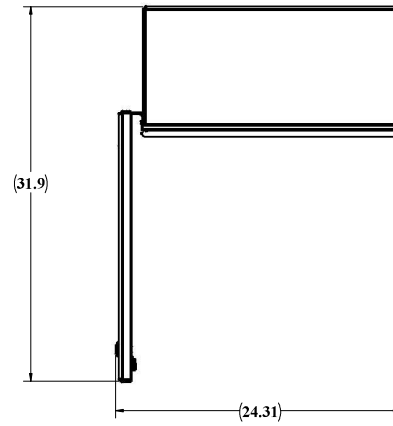

| UNLESS OTHERWISE SPECIFIED: | | | |
|--------------------------------------------|----------------------------|-------------------------------|--------------|
| DIMENSIONS ARE IN INCHES | | | |
| SBS-262210 | | | |
| ASSEMBLY | PROFESSIONAL | DATE | |
| DESIGNED BY | DATE | | |
| TRACED BY | DATE | | |
| INSTRUMENTED BY | DATE | | |
| ALL DIMENSIONS | UNLESS OTHERWISE SPECIFIED | | |
| MATERIALS SPECIFIED BY ALTA BROWN | | | |
| PAINT: BROWN/BLACK; BULK/BLACK/BLACK/BLACK | | | |
| DO NOT SCALE DRAWING | | | |
| DDB Unlimited Inc. | | SBS-262210 (Non UL/SBS-26219) | |
| REV | Code Code: | DWG. NO.: | REV |
| D | 26215 | 02305 | # |
| SCALE: 1:8 | | WEIGHT: 33.45 lbs. | SHEET 1 OF 2 |

UNCLASSIFIED PUBLIC

WEB DRAWING (NOT FOR FABRICATION)

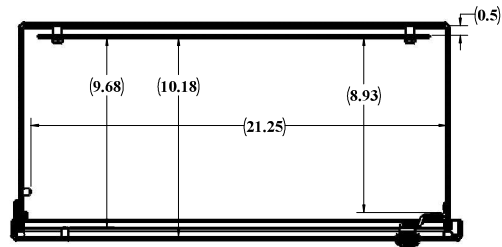
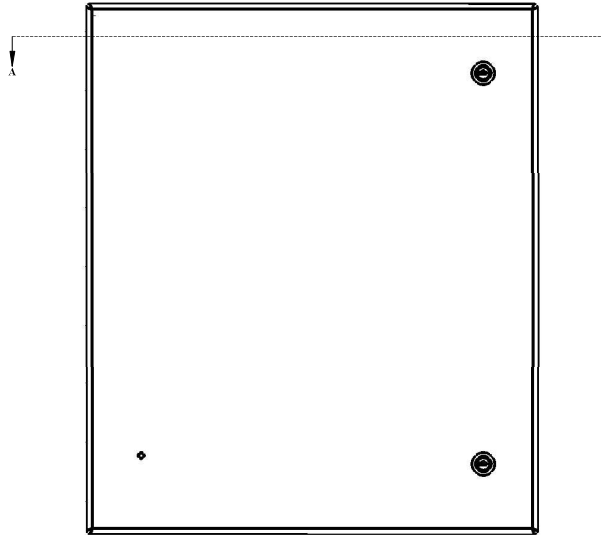

SECTION A-A
SCALE 1:3

WEB DRAWING (NOT FOR FABRICATION)

| | | | |
|---------------------------------------------------------|------|-----------------------------------------|------------|
| UNLESS OTHERWISE SPECIFIED: | | DDB Unlimited Inc. | |
| DIMENSIONS ARE IN INCHES | | SBS-262210 (closed) | |
| APPROXIMATE WEIGHT | 1.00 | SBS-262210 (Non LL) SBS-262210 (closed) | |
| DRY WEIGHT | 1.00 | REV | 02305 |
| WET WEIGHT | 1.00 | D | 28515 |
| ALL DIMENSIONS ARE TO CENTER UNLESS OTHERWISE SPECIFIED | | SCALE | 1:8 |
| MATERIAL SPECIFIED BY ALPHA SYMBOL | | WEIGHT | 33.44 lbs. |
| PAINT DIMENSIONS SHOWN UNLESS OTHERWISE SPECIFIED | | SHEET | 2 OF 2 |

UNCLASSIFIED PUBLIC

DDB FORM: 7.1.2 REV: A 08/02/17