

UL-50 OD SERIES

OD-16DXC-UL50

Why Choose the OD-UL Series?

The OD-16DXC-UL50 enclosures are the ultimate choice for your outdoor racking requirements. Being made of our own rugged Alumiflex®, you'll find it noticeably lighter than steel, yet strong enough to rack even the heaviest equipment. When choosing the OD-UL series, you have handpicked the highest value in American construction. The OD-UL series includes the standard features you have come to expect with DDB, incorporating the versatile R-strut system for adjustable racking, the security of a 3-point locking system, our patented Alumishield® solar cap to manage heat loads, door grounding strap, & UL listed gasketing. For those who need more than just our standard enclosure, DDB can also make a truly customized solution with our many available options including HVAC, providing a climate-controlled environment for any electronic equipment, electrical load panels and cable entry solutions to name a few. All of this comes together to create an enclosure able to meet all of the unique needs your customers have been seeking. DDB offers a state-of-the-art design, a competitive price, benchmark lead times and a guaranteed delivery, all backed up with an industry leading 15-year warranty on every enclosure. Put DDB's substantial stock to work for you today. Contact our professional staff to assist you with your made-to-order solution.



Features

- 15 Year Warranty
- 0.125" Aluminum Construction
- Welded Construction
- 3-Point Locking System
- Front and Rear Access
- Stainless Steel External Hardware/Hinge
- Custom Colors Available
- Water/Rain/Sleet/Dust Tight
- Flexible and Scalable
- Quick Shipping

Application Types

- Telecommunications
- Wireless/Broadband
 - Fiber Optics
 - Back Haul
 - Base Station
- Small Cell/ DAS
- Utility
- Public Safety
- Military
- Trailer-Based
- Communications
- Wi-Fi
- Flexible and Scalable
- LTEE/4G/5G
- Intelligent Traffic



Environmental & Safety Ratings:

- ✓ ETL environmentally listed to UL 50/50E, IP 66, Type 4
- ✓ ETL listed; Safety Requirements, UL 62368-1:2019 Ed.3, CSA C22.2

Weight and Dimensions

- Approximate Exterior Enclosure Dimensions:
 - 18"H x 29"W x 30"D
- Shipping Dimensions:
 - 42"L x 32"W x 26"H- Palletized
- Approximate Shipping Weight:
 - 72 lbs.

UL-50 OD SERIES

OD-16DXC-UL50

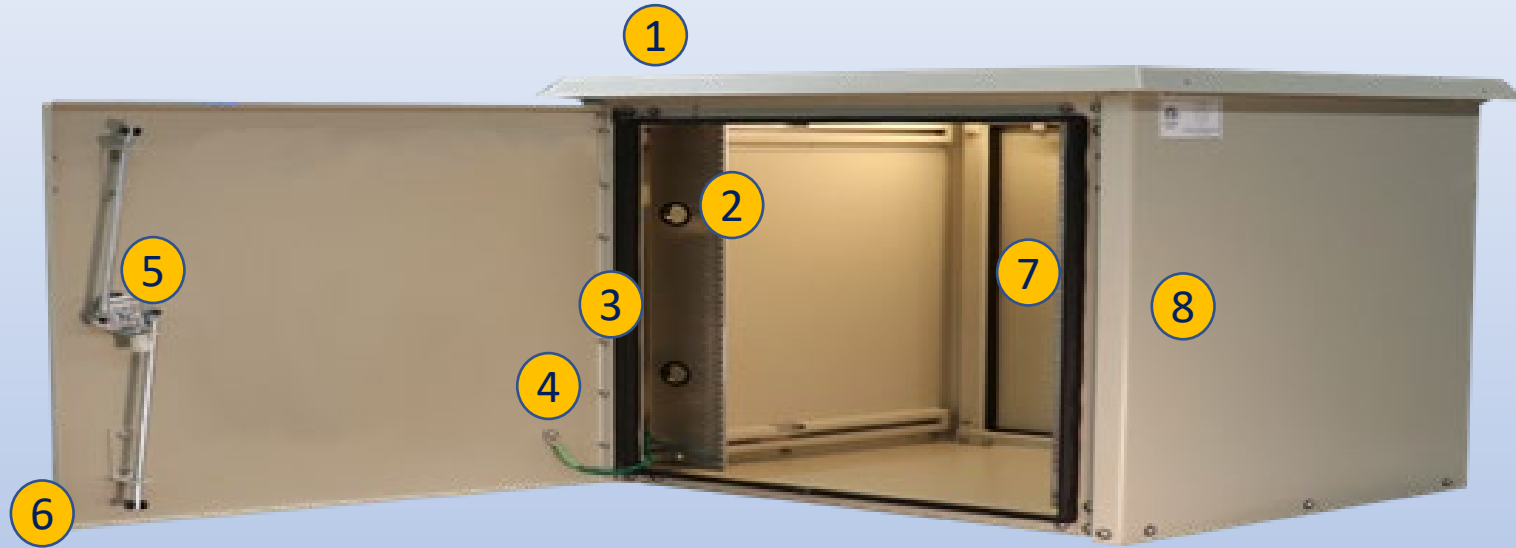

Features

1. Alumishield Solar Cap
2. 19" Adjustable Racking Rails
3. Stainless Steel Door Hinge
4. Door Grounding Strap
5. 3-Point Locking System
6. 0.125" Aluminum Construction
7. Rear Door Access
8. Powder Coat Finish

Scan this code for
Climate Control



Scan this code for
Accessories

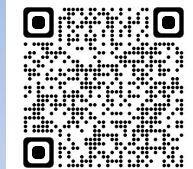

2301 S. HWY 77 Pauls Valley, OK 73075

T: (405)-665-2876

sales@ddbunlimited.com www.ddbunlimited.com

REVISIONS		
REV.	DESCRIPTION	DATE
A	OD-16DX-UL50	9/11/2018
B	UPDATED SHEET FORMAT	3/28/2022

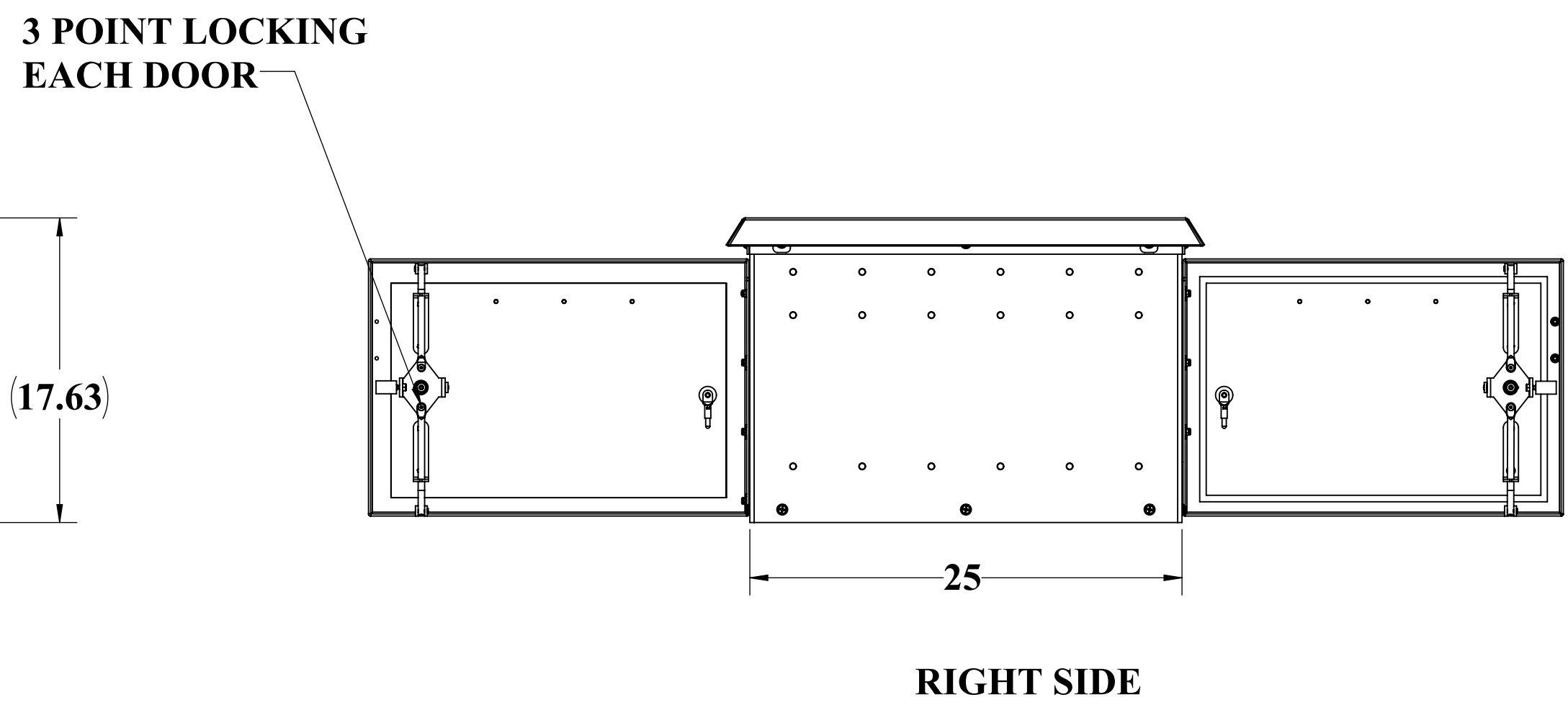
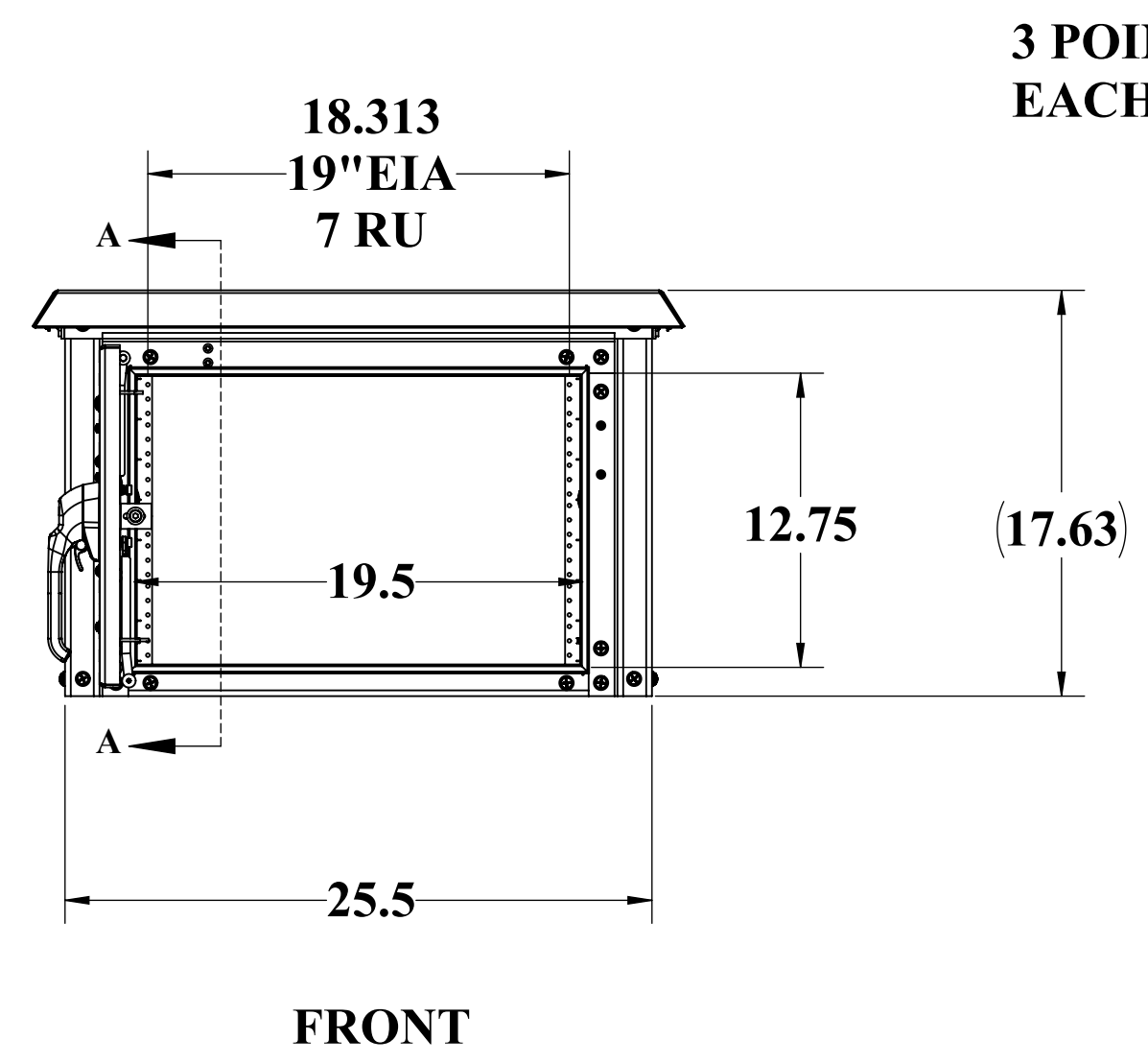
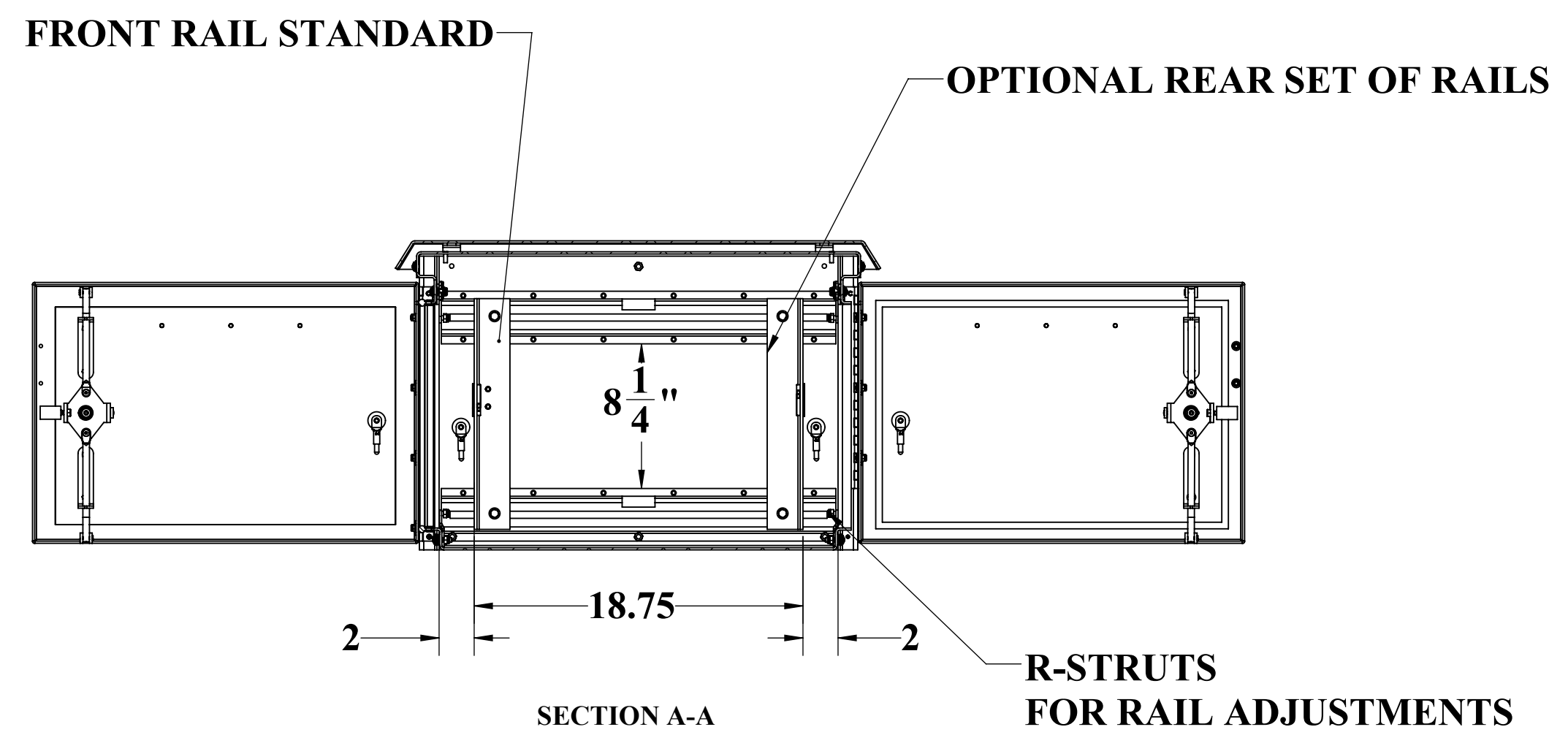
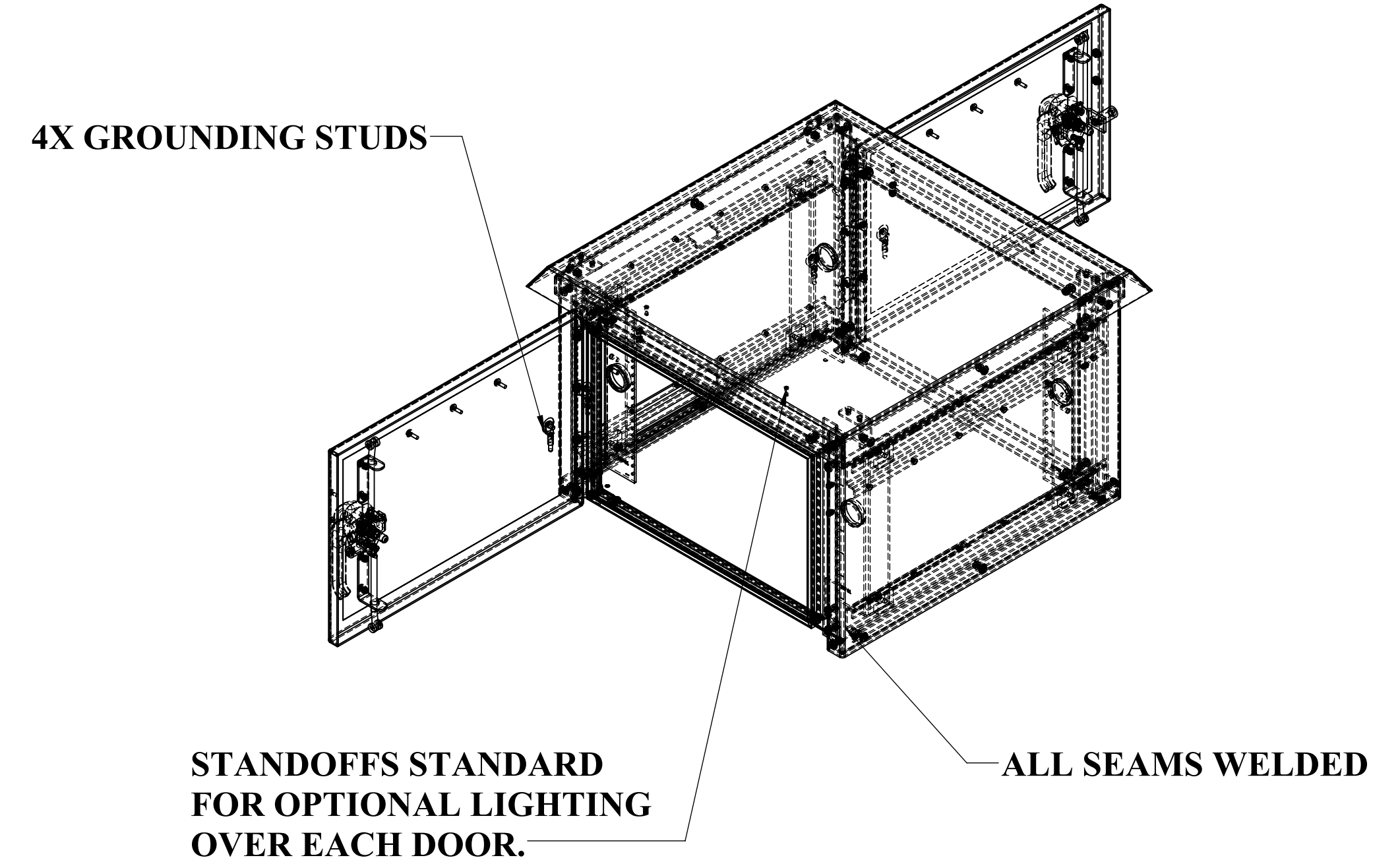
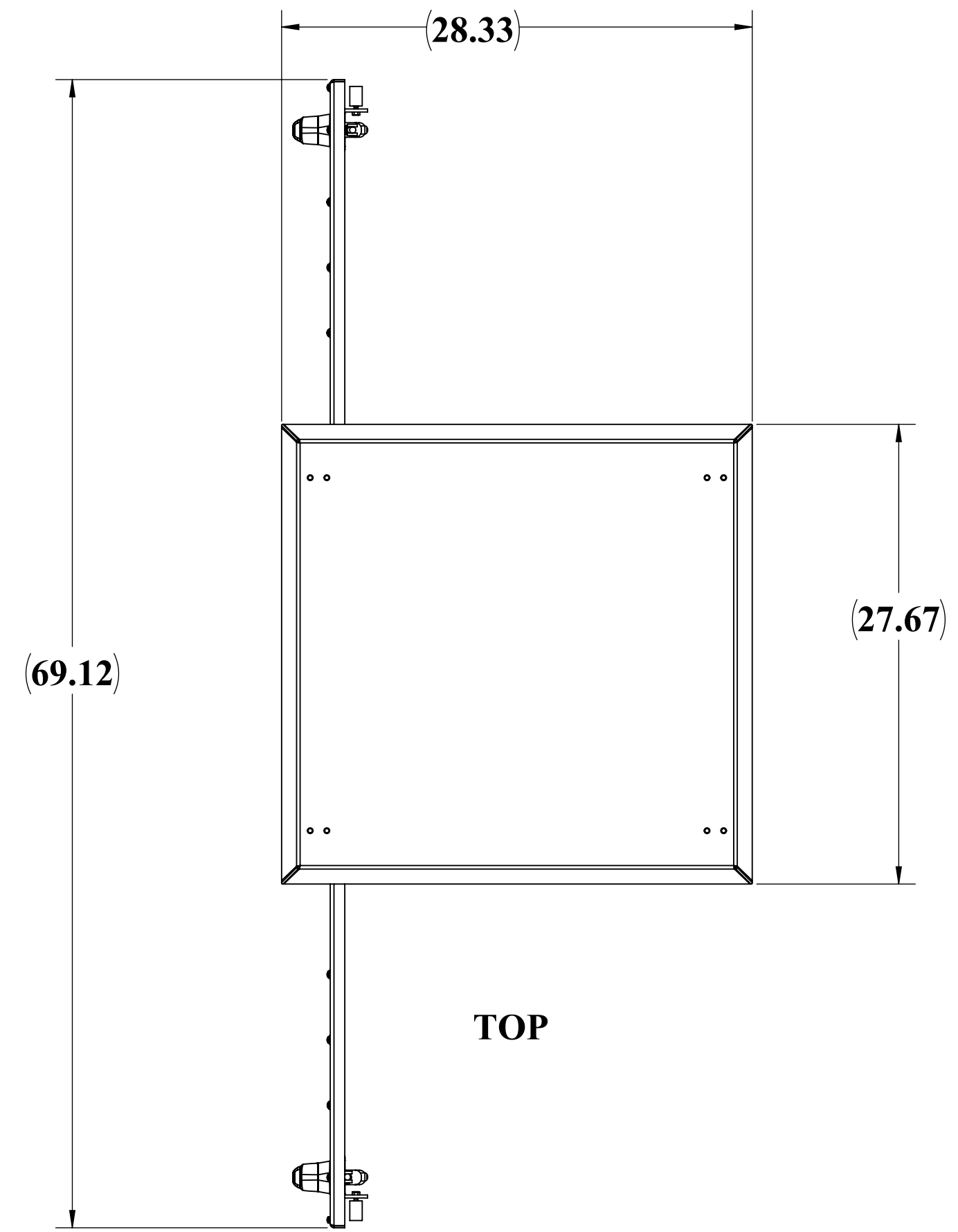

UNLESS OTHERWISE SPECIFIED:			
DIMENSIONS ARE IN INCHES			
ANGULAR:	± 1°		
FRACTIONAL NO DECIMAL:	± 1/1250		
ONE PLACE DECIMAL:	± 0.0025		
TWO PLACE DECIMAL:	± 0.0050		
THREE PLACE DECIMAL:	± 0.0100		
ALL HOLES: ± 0.0030 Ø.			
MATERIAL:	5052-H32-0.125 ASTM B209-04		
PAINT: DIAMOND VOGEL BEIGE GLOSS TEXTURE ET-8320			
DO NOT SCALE DRAWING			
DDB Unlimited Inc.			
OD-16DX-UL50			
SIZE	Cage Code:	DWG. NO.:	REV
D	385Y5	01842	B
SCALE: 1:8		WEIGHT: 63 lbs.	SHEET 1 OF 3

09/19/24

8 7 6 5 4 3 2 1

H G F E D C B A

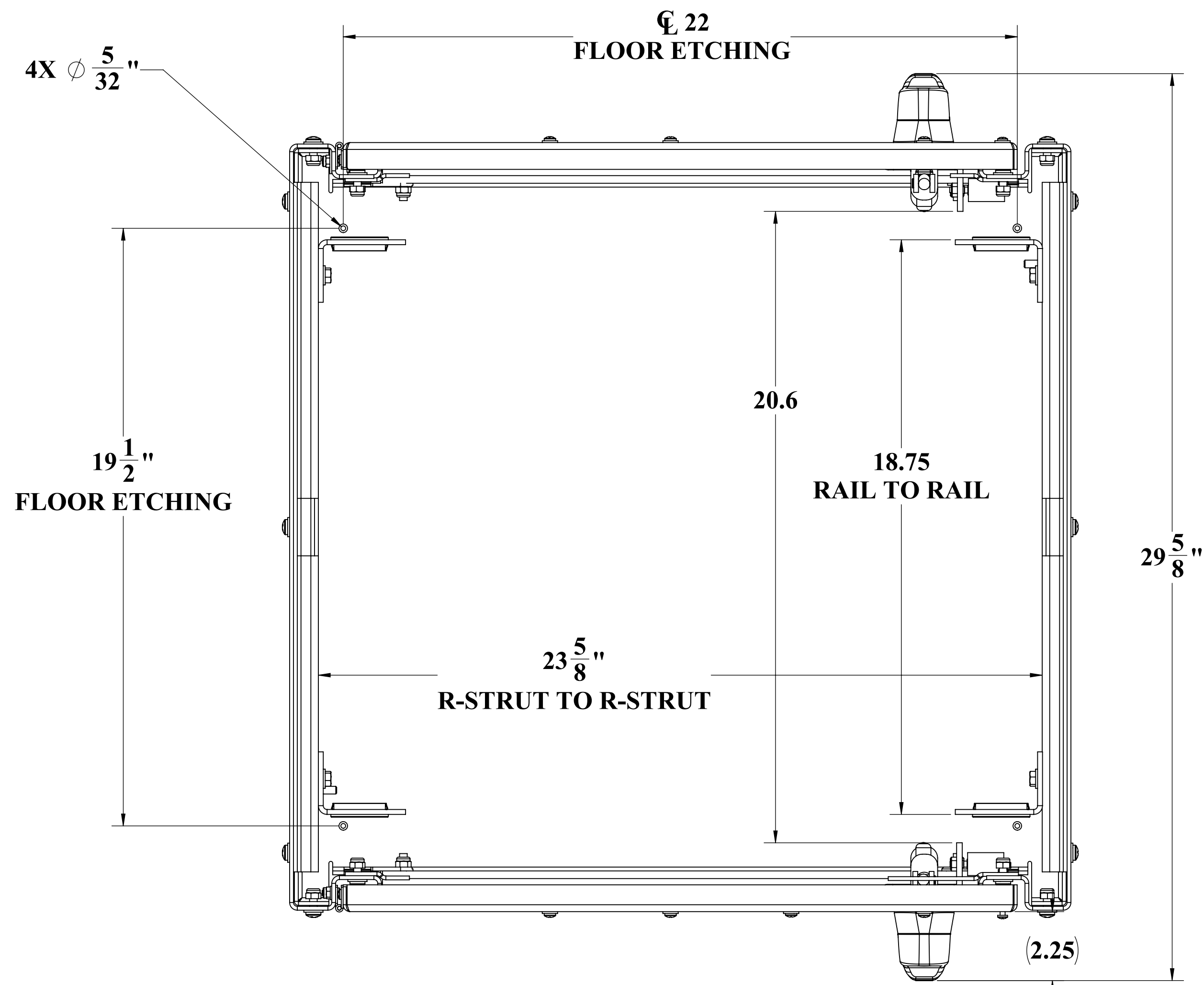

TOP VIEW CEILING AND ALUMASHIELD NOT SHOWN

UNLESS OTHERWISE SPECIFIED:		DDB Unlimited Inc.	
DIMENSIONS ARE IN INCHES		OD-DX-Closed	
ANGULAR:	±1°	SIZE	Cage Code:
FRACTIONAL/NO DECIMAL:	±0.1250	D	385Y5
ONE PLACE DECIMAL:	±0.0025	DWG. NO.:	01842
TWO PLACE DECIMAL:	±0.0050	REV	B
THREE PLACE DECIMAL:	±0.0100	SCALE:	1:8
ALL HOLES:	±0.0030 Ø.	WEIGHT:	87 lbs.
MATERIAL:	5052-H32-0.125 ASTM B209-04	SHEET 2 OF 3	
PAINT:	DIAMOND VOGEL BEIGE GLOSS TEXTURE ET-8320	DO NOT SCALE DRAWING	

UNCLASSIFIED PUBLIC

09/19/24

8 7 6 5 4 3 2 1

H
G
F
E
D
C
B
A

DOOR GASKET HIDDEN

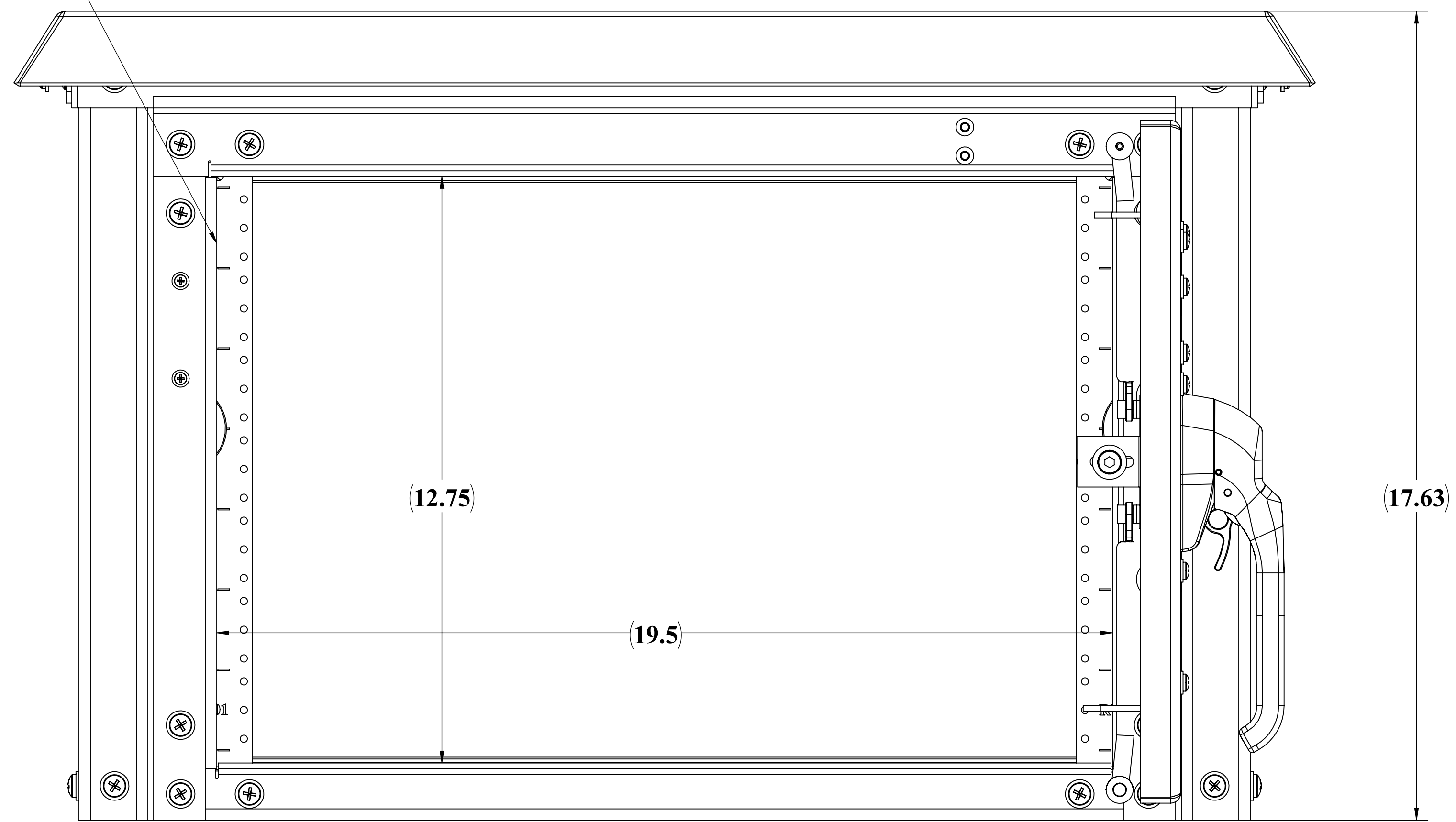

BACK VIEW

UNLESS OTHERWISE SPECIFIED:		DDB Unlimited Inc.	
DIMENSIONS ARE IN INCHES		OD-16DX-UL50	
ANGULAR:	±1°	SIZE	Cage Code: DWG. NO.: REV
FRACTIONAL/NO DECIMAL:	±0.1250	D	385Y5 01842 B
ONE PLACE DECIMAL:	±0.0025	SCALE: 1:8	WEIGHT: 63 lbs.
TWO PLACE DECIMAL:	±0.0050	SHEET 3 OF 3	
THREE PLACE DECIMAL:	±0.0100		
ALL HOLES: ±0.0030 Ø.			
MATERIAL: 5052-H32-0.125 ASTM B209-04			
PAINT: DIAMOND VOGEL BEIGE GLOSS TEXTURE ET-8320			
DO NOT SCALE DRAWING			

UNCLASSIFIED PUBLIC

09/19/24