

UL-50 OD SERIES

OD-30DXC-UL50

Why Choose the OD-UL Series?

The OD-30DXC-UL50 enclosures are the ultimate choice for your outdoor racking requirements. Being made of our own rugged Alumiflex®, you'll find it noticeably lighter than steel, yet strong enough to rack even the heaviest equipment. When choosing the OD-UL series, you have handpicked the highest value in American construction. The OD-UL series includes the standard features you have come to expect with DDB, incorporating the versatile R-strut system for adjustable racking, the security of a 3- point locking system, our patented Alumishield® solar cap to manage heat loads, door grounding strap, & UL listed gasketing. For those who need more than just our standard enclosure, DDB can also make a truly customized solution with our many available options including HVAC, providing a climate-controlled environment for any electronic equipment, electrical load panels and cable entry solutions to name a few. All of this comes together to create an enclosure able to meet all of the unique needs your customers have been seeking. DDB offers a state-of-the-art design, a competitive price, benchmark lead times and a guaranteed delivery, all backed up with an industry leading 15-year warranty on every enclosure. Put DDB's substantial stock to work for you today. Contact our professional staff to assist you with your made-to-order solution.



Features

- 15 Year Warranty
- 0.125" Aluminum Construction
- Welded Construction
- 3-Point Locking System
- Front and Rear Access
- Stainless Steel External Hardware/Hinge
- Custom Colors Available
- Water/Rain/Sleet/Dust Tight
- Flexible and Scalable
- Quick Shipping

Application Types

- Telecommunications
- Wireless/Broadband
 - Fiber Optics
 - Back Haul
- Base Station
- Small Cell/ DAS
- Utility
- Public Safety
- Military
- Trailer-Based
- Communications
- Wi-Fi
- Flexible and Scalable
- LTEE/4G/5G
- Intelligent Traffic



Environmental & Safety Ratings:

- ✓ ETL environmentally listed to UL 50/50E, IP 66, Type 4
- ✓ ETL listed; Safety Requirements, UL 62368-1:2019 Ed.3, CSA C22.2

Weight and Dimensions

- Approximate Exterior Enclosure Dimensions:
32"H x 29"W x 30"D
- Shipping Dimensions:
42"L x 32"W x 40"H- Palletized
- Approximate Shipping Weight:
150 lbs.

UL-50 OD SERIES

OD-30DXC-UL50

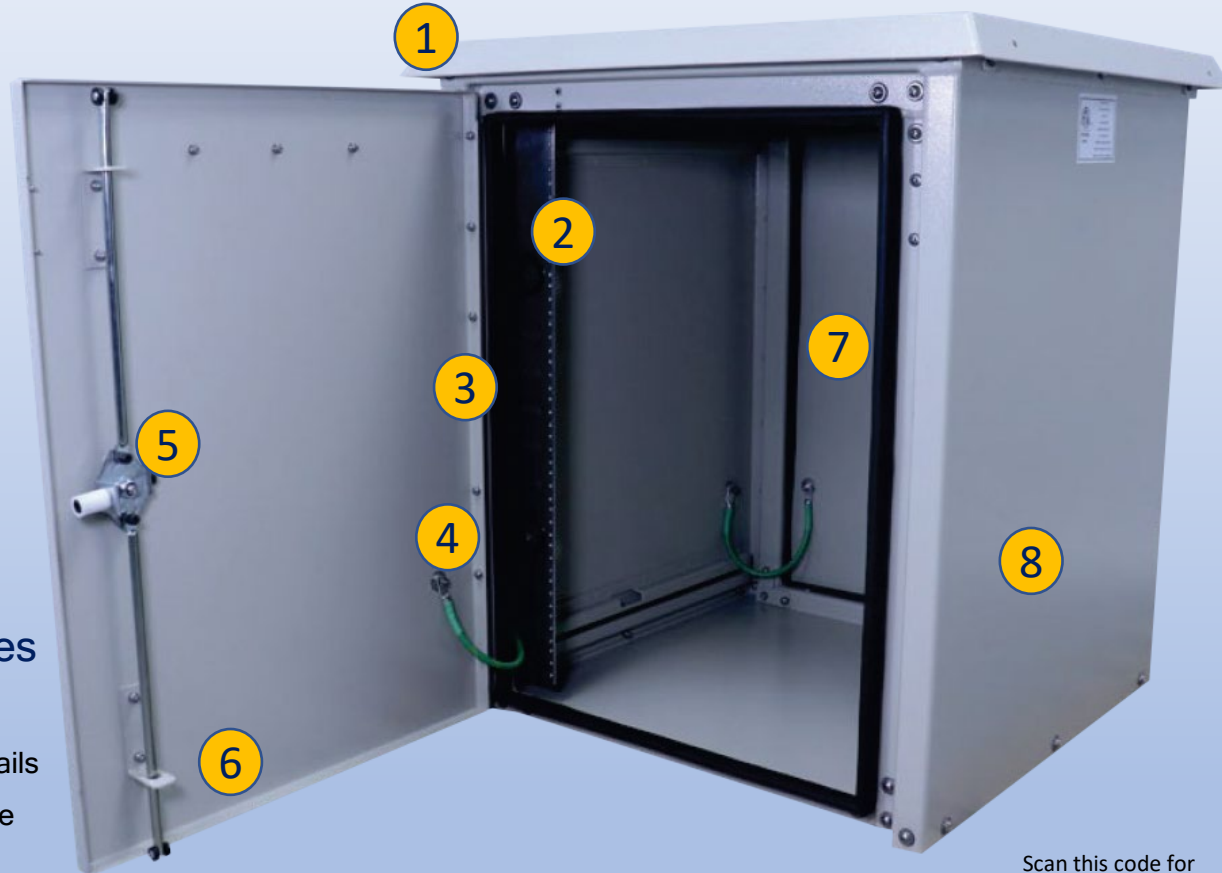

Features

1. Alumishield Solar Cap
2. 19" Adjustable Racking Rails
3. Stainless Steel Door Hinge
4. Door Grounding Strap
5. 3-Point Locking System
6. 0.125" Aluminum Construction
7. Rear Door Access
8. Powder Coat Finish

2301 S. HWY 77 Pauls Valley, OK 73075

T: (405)-665-2876

sales@ddbunlimited.com www.ddbunlimited.com

Scan this code for
Climate Control



Scan this code for
Accessories

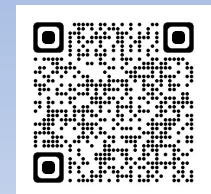

TGXUQPU		
TGX0	FGUETRVRQP	FCVG
C	ETGCVGF'Y GDUR/G'FTCY RPI 'QF/52FZ/ WN72	; B4H23:
D	WRF CVGF 'UI GGV'HQTO CV	5H: H244

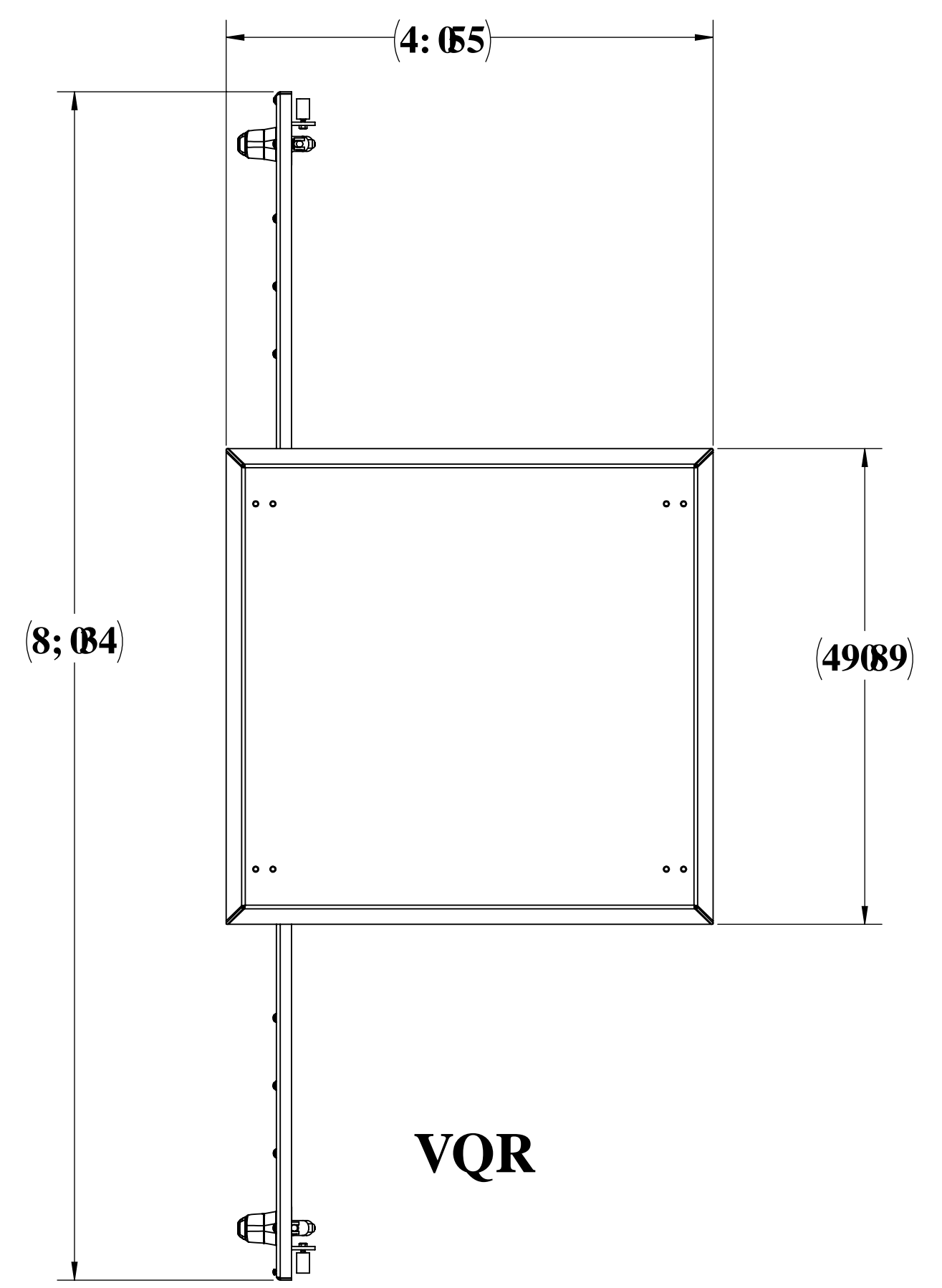

UVC PF QHHU'UVC PF CTF
 HQT'QRVQPCN'NH J VRPI
 QXGT'GCEJ 'FQQT0

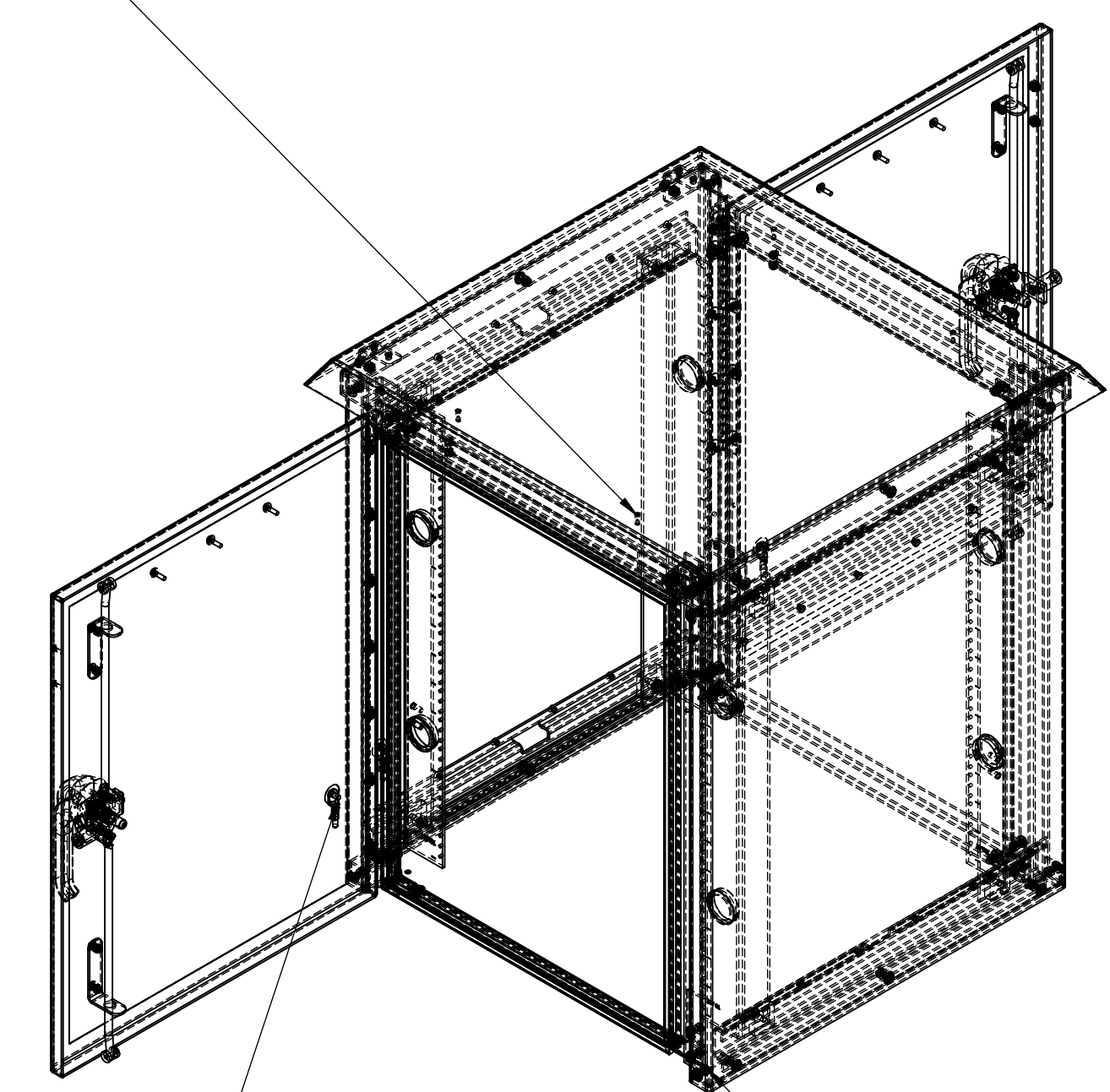

6Z'I TQWPF RPI 'UVWFU

CNN'UGCO UY GNF GF

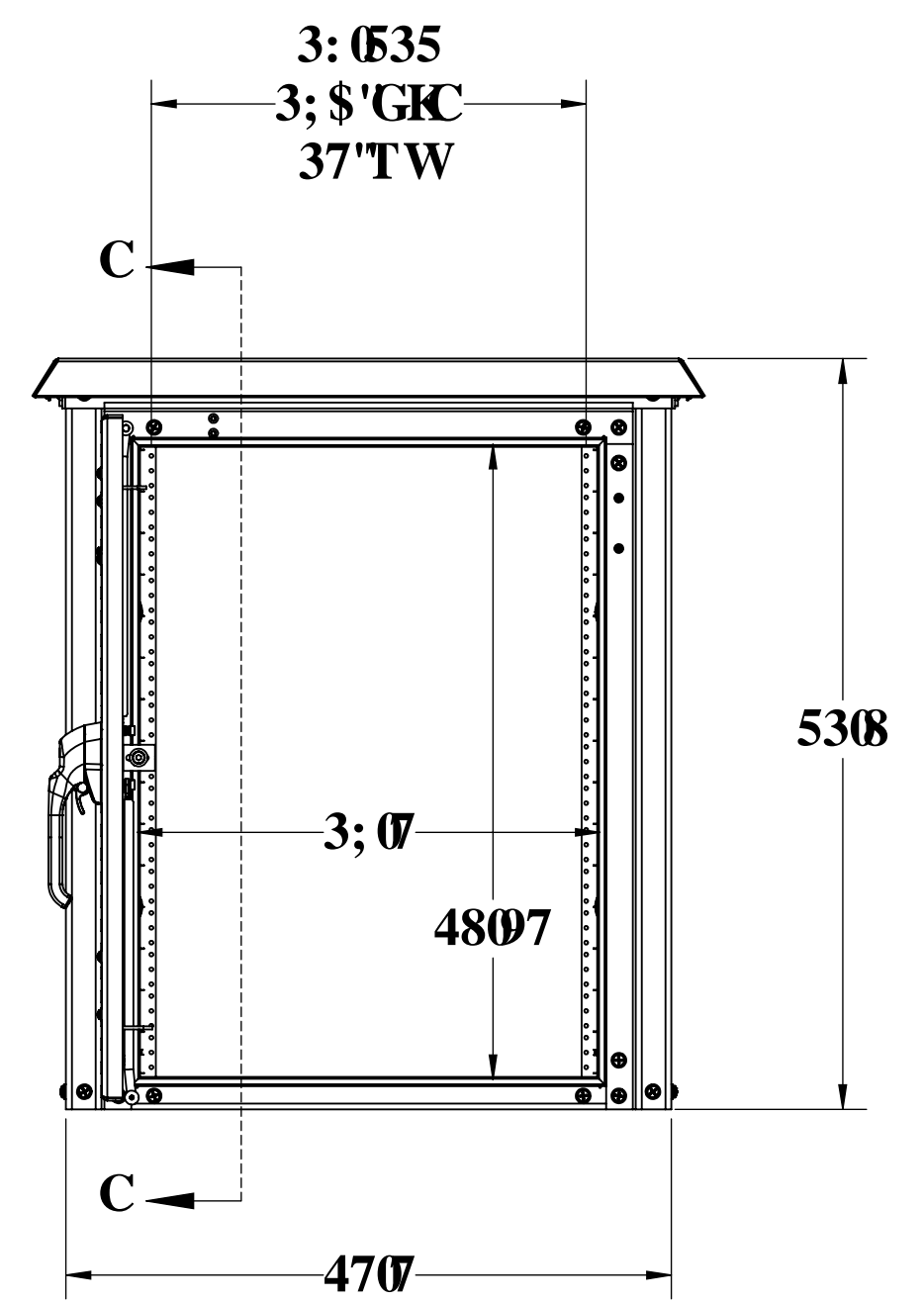
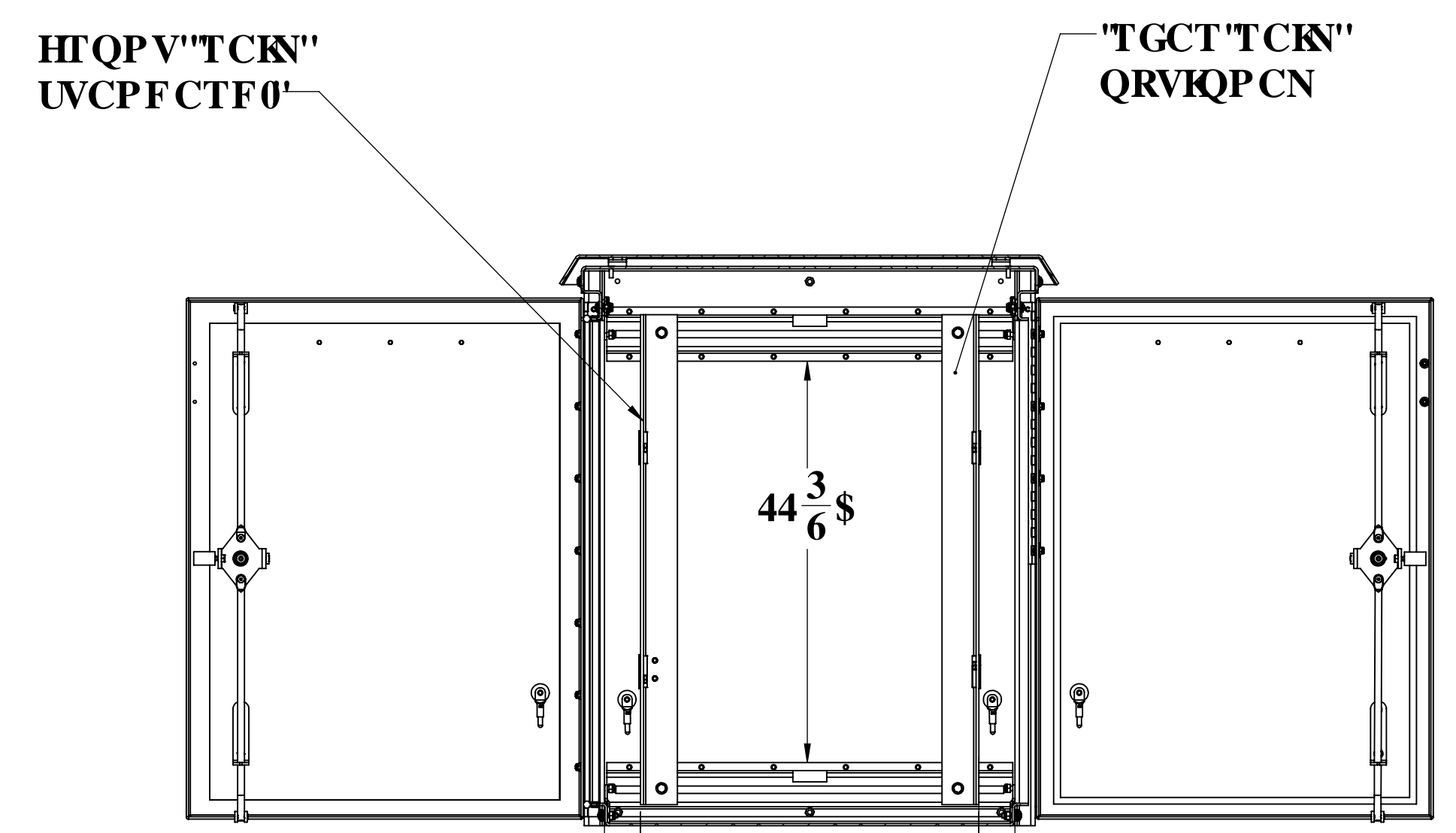

5'RQP V'NQEM RPI
GCEJ 'FQQT

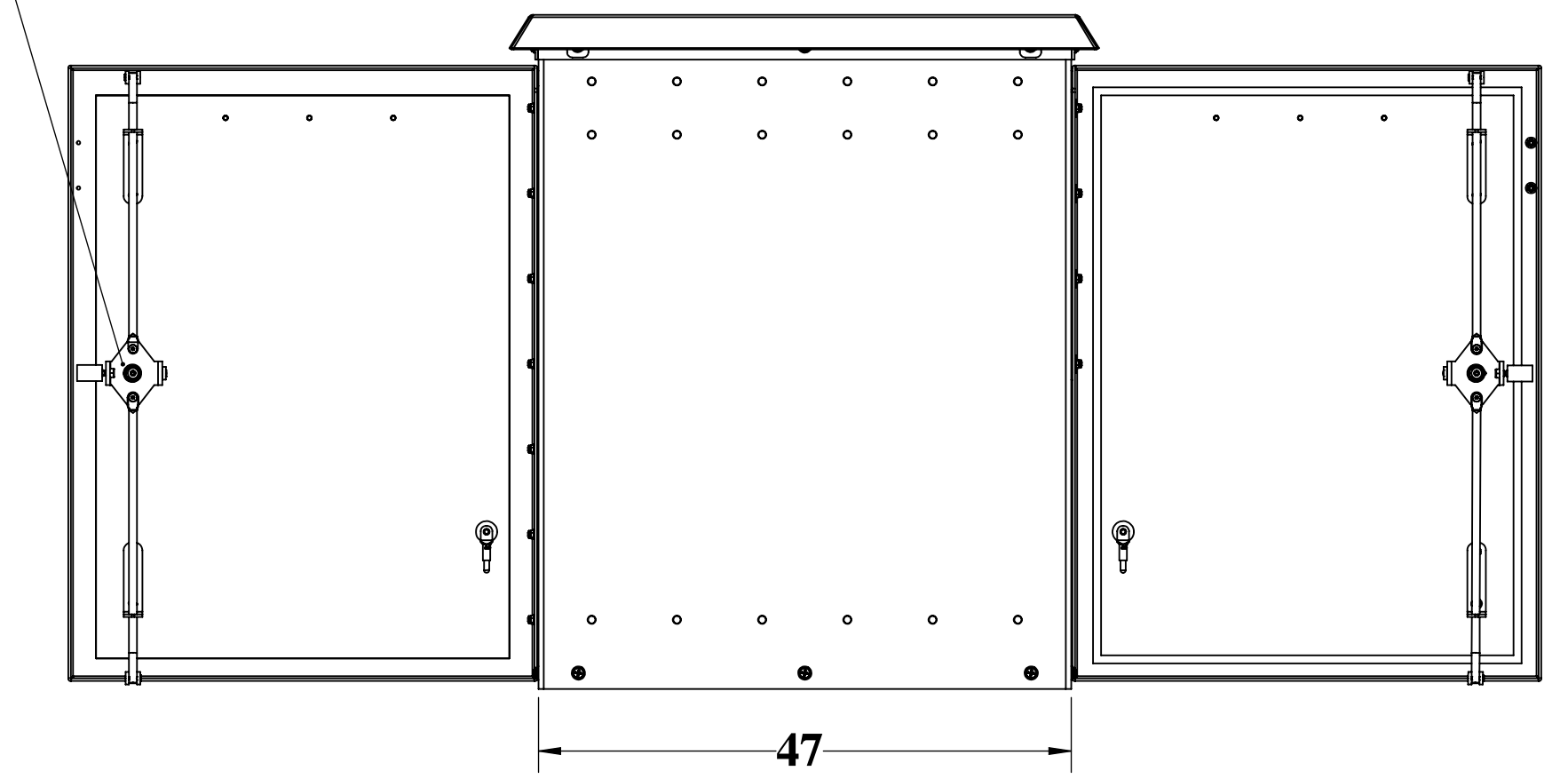

I B7@GG#-98'DI 6@7		8861 b'p JYX-bW	
C8' SBL11 @ S		C8' SBL11 @ S	
GNP	7U[Y 7cXY.	BK: "BC"	F9J
8	' ,)M	\$% ('	6
G7 5@% , K 9: <H, +Vg'		G-99%G: "	

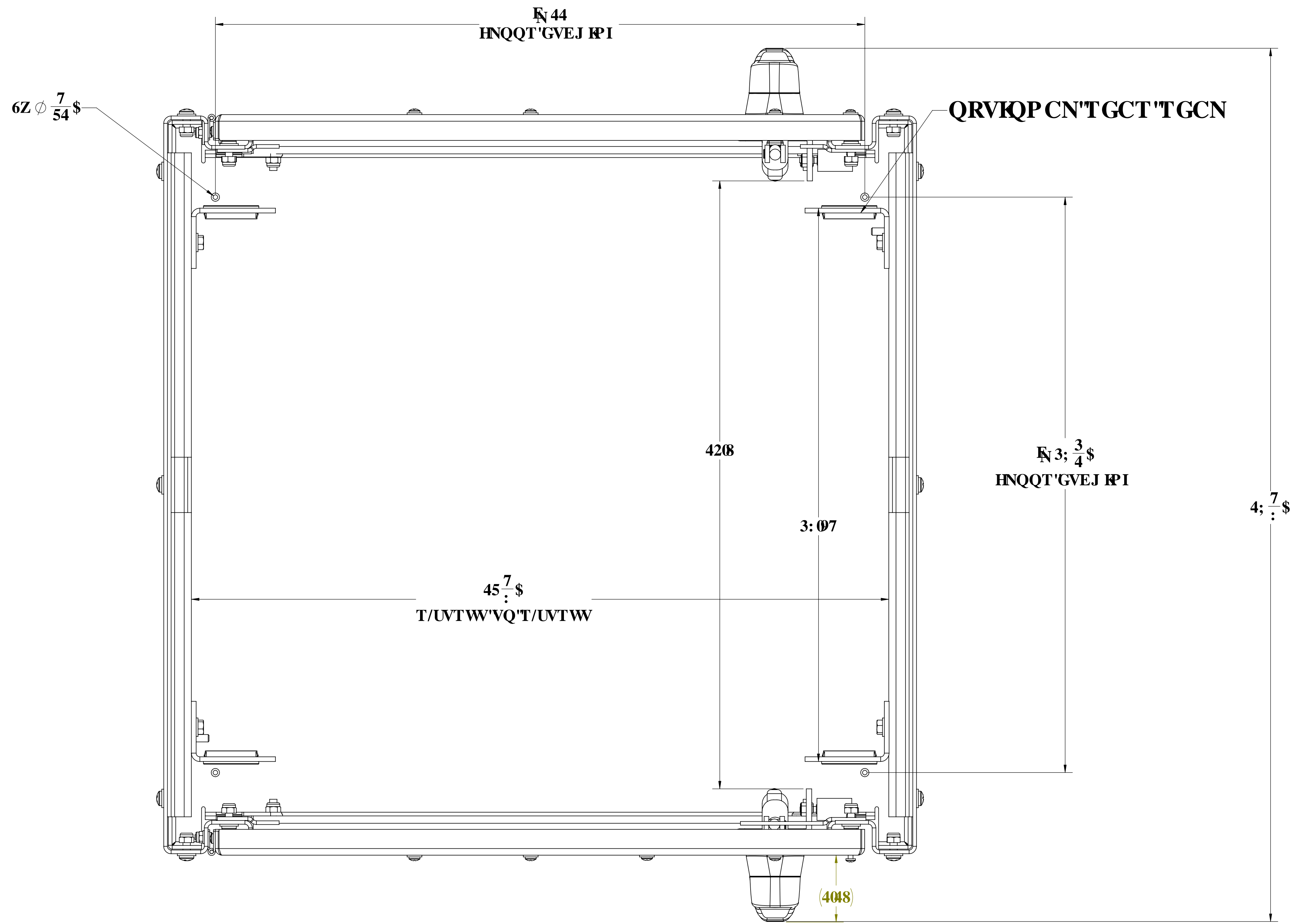

HCD'J-9K '79-@B; '5B8'5 @ A5G<-9 @ 'BCH'G<CK B

I B7 @GG-98 DI 6@7

I B7@GG-98 DI 6@7		8861 b'j YX-bW	
C818L17 cgyX			
GNP	7U[Y7cXY.	BK: "BC"	F9J
8	' ,)M	\$% ('	6
BC BCHG7 5@98F5K-B		G7 5@% , K 9: <H, +Vg'	G-9948.C: "

