

UL-50 OD SERIES

OD-50DDC-UL50

Why Choose the OD-UL Series?

The OD-50DDC-UL50 enclosures are the ultimate choice for your outdoor racking requirements. Being made of our own rugged Alumiflex®, you'll find it noticeably lighter than steel, yet strong enough to rack even the heaviest equipment. When choosing the OD-UL series, you have handpicked the highest value in American construction. The OD-UL series includes the standard features you have come to expect with DDB, incorporating the versatile R-strut system for adjustable racking, the security of a 3-point locking system, our patented Alumishield® solar cap to manage heat loads, door grounding strap, & UL listed gasketing. For those who need more than just our standard enclosure, DDB can also make a truly customized solution with our many available options including HVAC, providing a climate-controlled environment for any electronic equipment, electrical load panels and cable entry solutions to name a few. All of this comes together to create an enclosure able to meet all of the unique needs your customers have been seeking. DDB offers a state-of-the-art design, a competitive price, benchmark lead times and a guaranteed delivery, all backed up with an industry leading 15-year warranty on every enclosure. Put DDB's substantial stock to work for you today. Contact our professional staff to assist you with your made-to-order solution.



Features

- 15 Year Warranty
- 0.125" Aluminum Construction
- Welded Construction
- 3-Point Locking System
- Front and Rear Access
- Stainless Steel External Hardware/Hinge
- Custom Colors Available
- Water/Rain/Sleet/Dust Tight
- Flexible and Scalable
- Quick Shipping

Application Types

- Telecommunications
- Wireless/Broadband
 - Fiber Optics
 - Back Haul
 - Base Station
- Small Cell/ DAS
- Utility
- Public Safety
- Military
- Trailer-Based
- Communications
 - Wi-Fi
- Flexible and Scalable
 - LTEE/4G/5G
- Intelligent Traffic



Environmental & Safety Ratings:

- ✓ ETL environmentally listed to UL 50/50E, IP 66, Type 4
- ✓ ETL listed; Safety Requirements, UL 62368-1:2019 Ed.3, CSA C22.2

Weight and Dimensions

Approximate Exterior Enclosure Dimensions:

51"H x 29"W x 39"D

Shipping Dimensions:

42"L x 32"W x 60"H- Palletized

Approximate Shipping Weight:

200 lbs.

UL-50 OD SERIES

OD-50DDC-UL50



Features

1. Alumishield Solar Cap
2. 19" Adjustable Racking Rails
3. Stainless Steel Door Hinge
4. Door Grounding Strap
5. 3-Point Locking System
6. 0.125" Aluminum Construction
7. Rear Door Access
8. Powder Coat Finish

2301 S. HWY 77 Pauls Valley, OK 73075

T: (405)-665-2876

sales@ddbunlimited.com www.ddbunlimited.com

Scan this code for
Climate Control



Scan this code for
Accessories

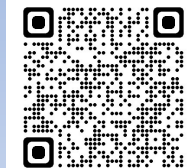

| TGXHQPU | | |
|---------|---|----------|
| TGX0 | FGUETRRVQP | FCVG |
| C | ETGCVGF'Y GDUS'G'FTCY R'P I 'HQT'QF/72FF/ WN72'RGT'F/T/23:72 | ; H8H23: |
| D | WRFCVGF'UJ GGV'HQTO CV | 5H; H244 |

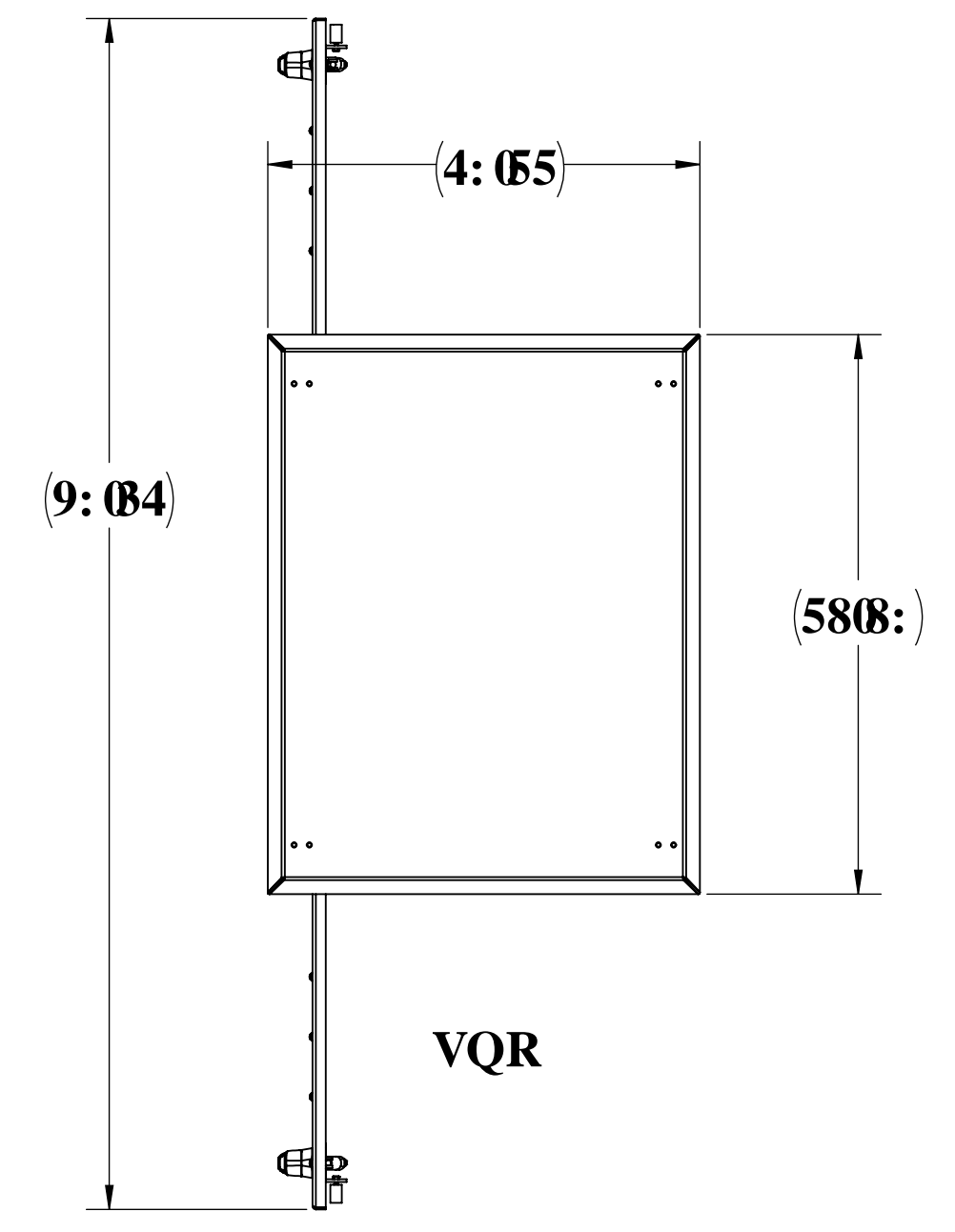

UVC PF QHHUVC PF CTF
HQT'QRVQP CN'NH J VPI
QXGT'GCEJ 'FQQT0

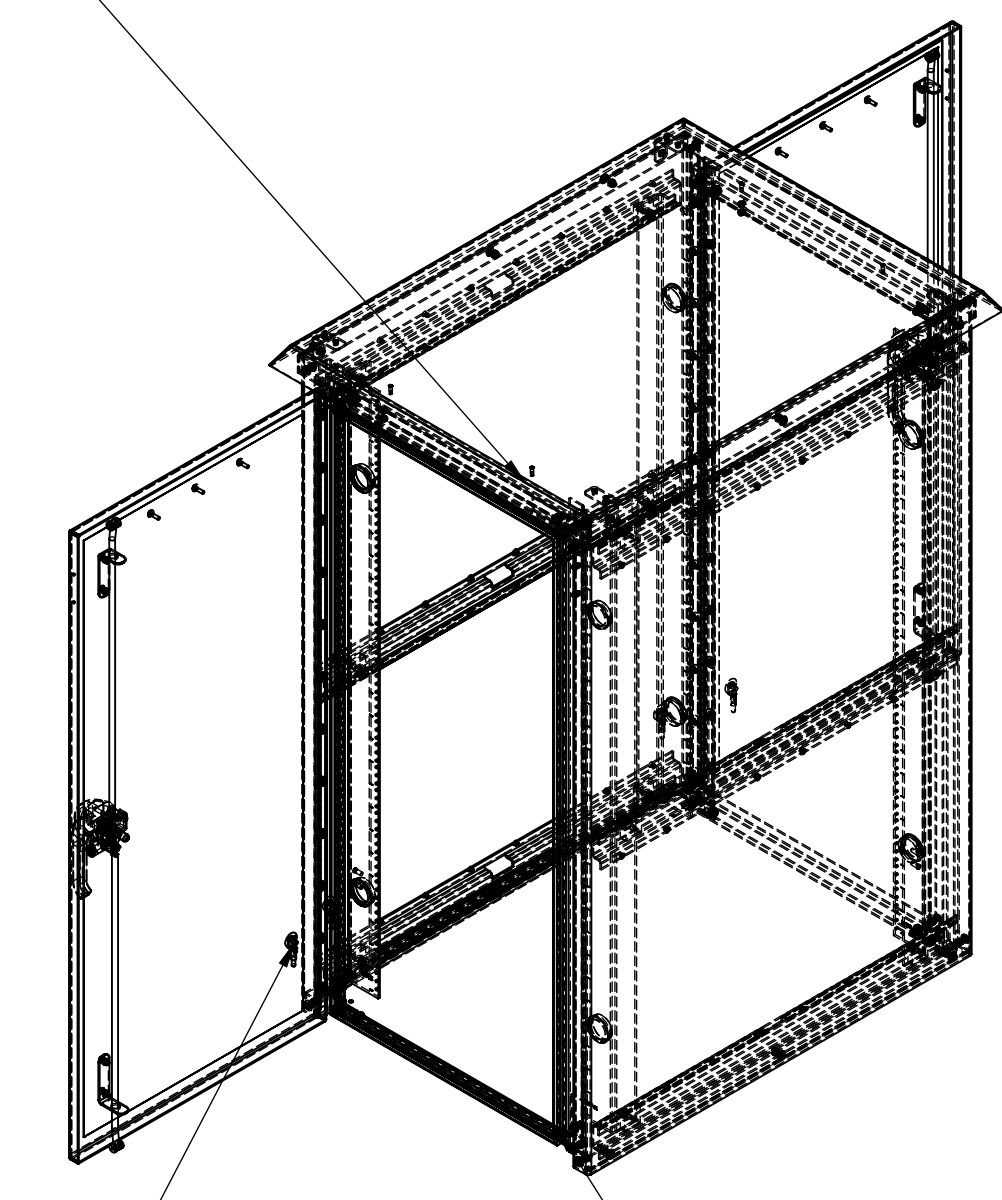

6Z'I TQWPFPI 'UVWFU

CNN'UGCO UY GNF GF

HTQPV'CPF'TGCT'TCKNU
UVC PF CTF

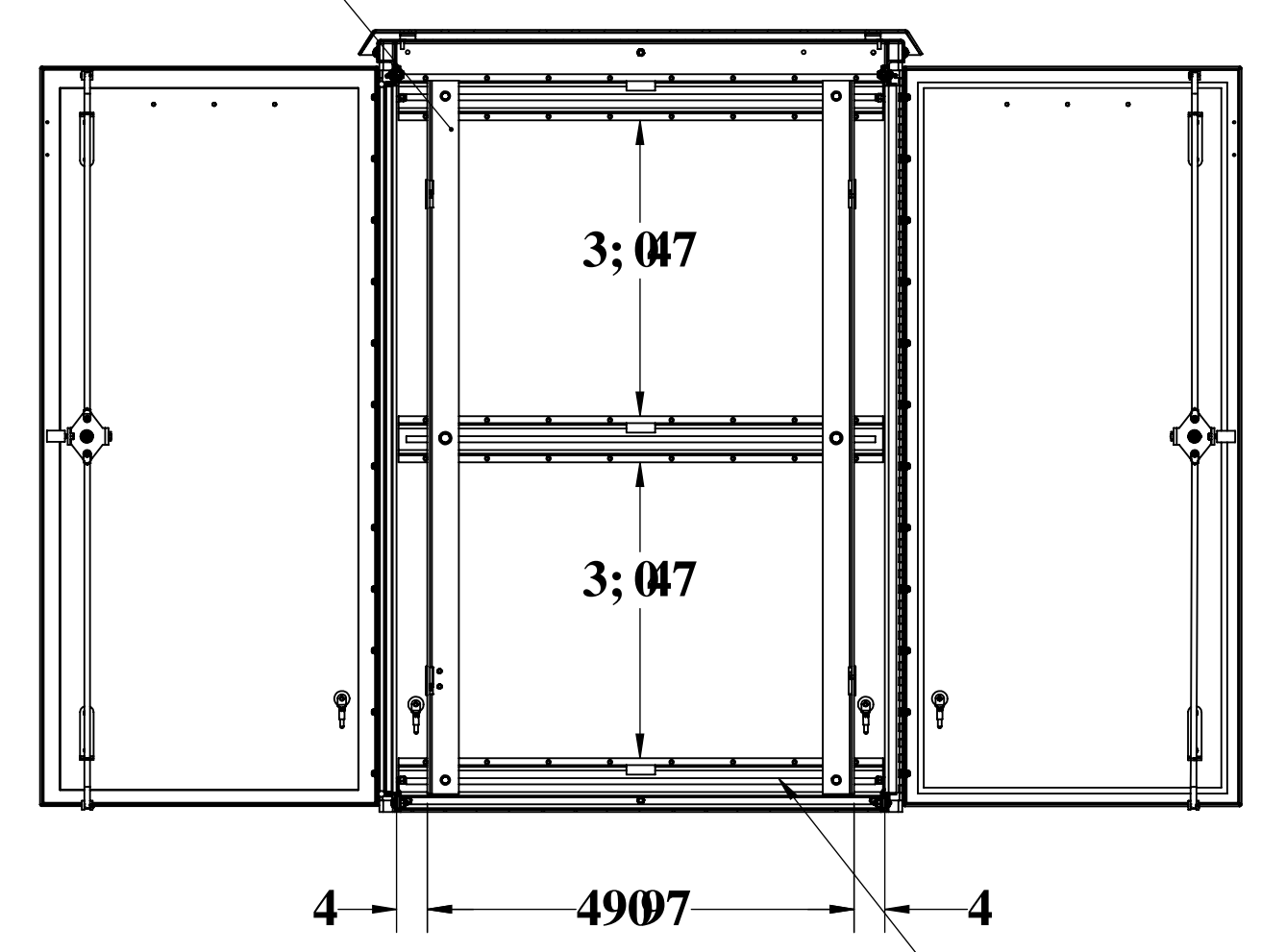

UGEVKQP'C/C
T/UVTWU
HQT'TCKN'CFLWUVO GPVU

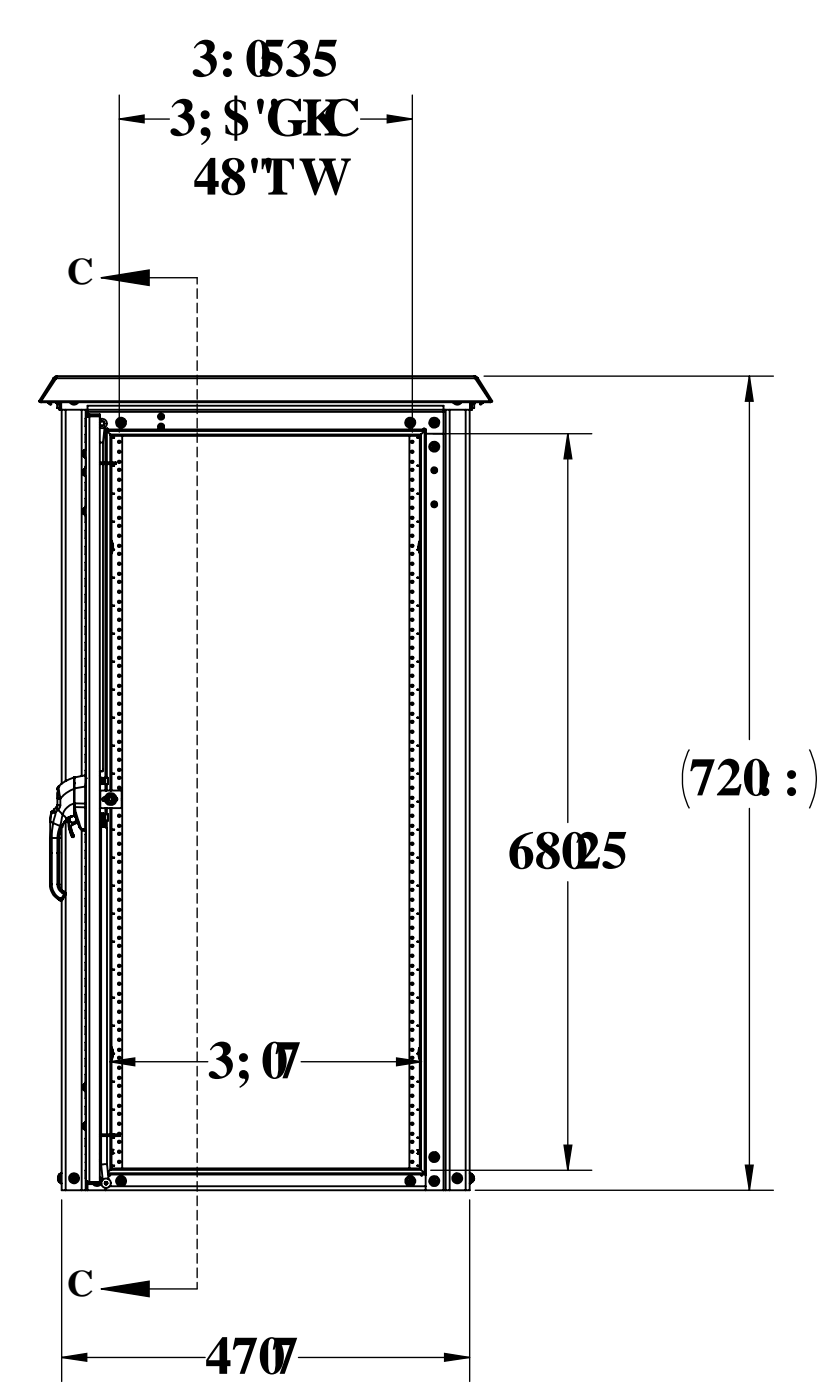

HTQP V

5'RQF'VNQEMPI
GCEJ 'FQQT

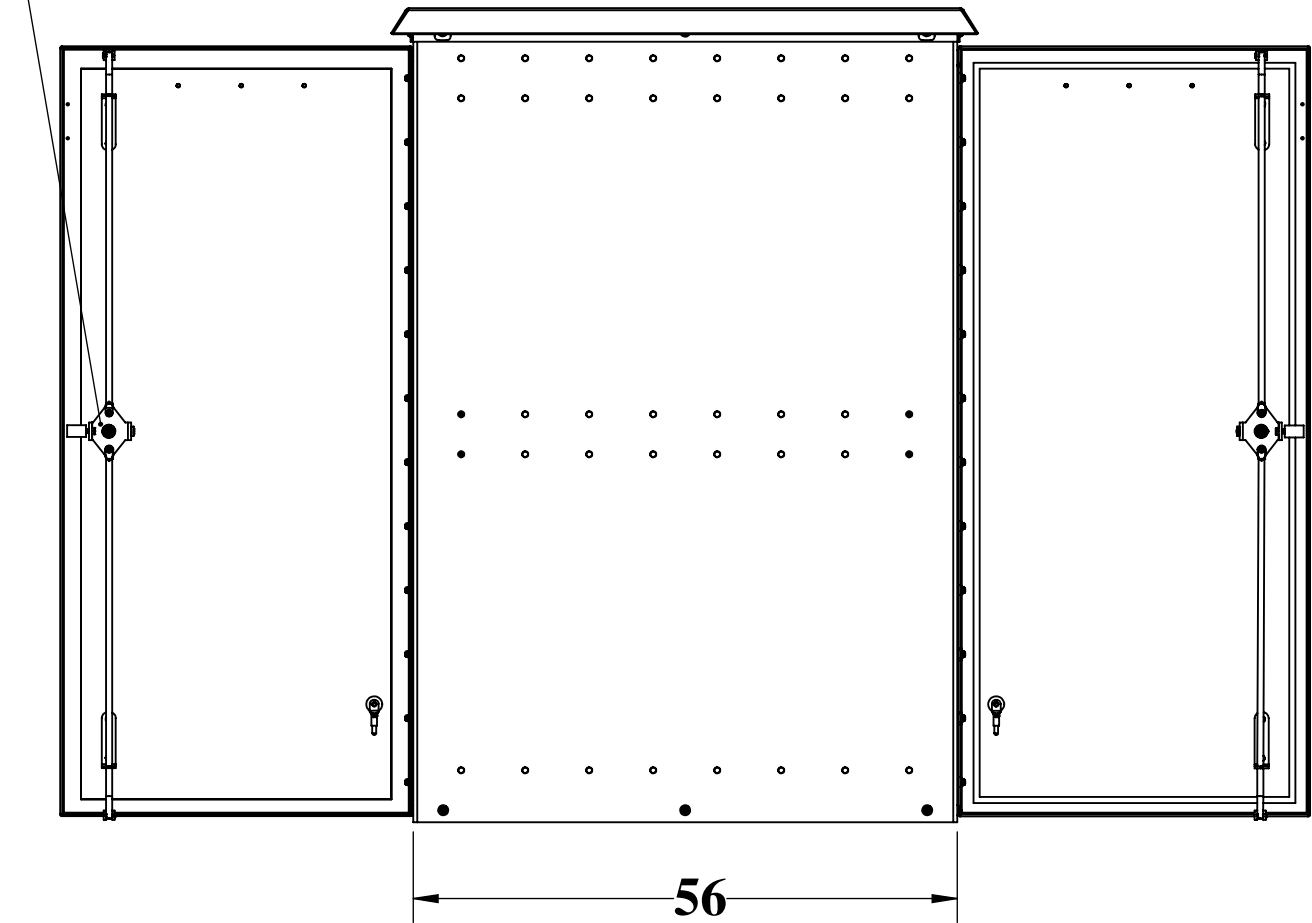

TH J VUFG

| | | | |
|---|--------------------|-----------------|-----------------|
| I B70CGG-98 DI 607 | | 8861 b'p JYX-bW | |
| BA WOCBOSV 4-07-00 | | C81) S8811 @ \$ | |
| SD: 1.8F | 757MCSMBC 007 A 50 | GNP | 7U[Y 7cXY. |
| CDPBE 7000 A 50 | 1 3300 S | 8 | ' ,)M |
| K C D07 7000 A 50 | 1 3300 S | BC | ' \$%) \$ |
| H 10000 7000 A 50 | 1 3300 S | G7 50% | %% K 9: <H%) Vg |
| 500:CGM:5532 10* | | | G-994%G: * |
| A 5HF-50 @) \$) 2' 21 \$%0 5GA 605-1S(| | | |
| D5-BH 85ACB7C: 0000 9: 4000LH P9H: 85 | | | |
| BC BCHG7 5@98F5K-B: | | | |

FQQT'I CUMGV'J K'FGP

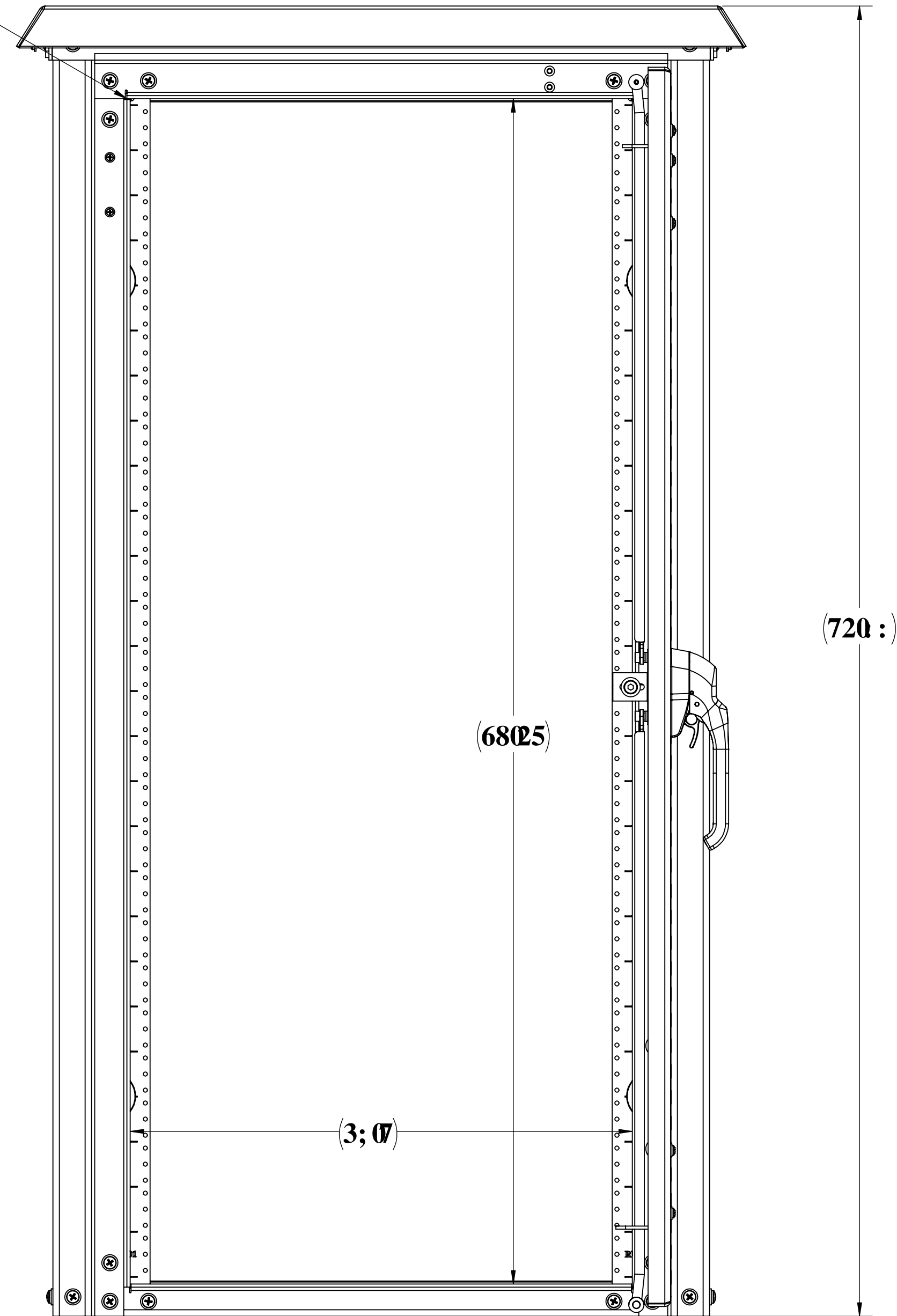

DCEM'XIGY

| | | | |
|------------------------------|------------|--------------------|-----|
| I B'9KGC'H'9FK-09'0077 ± 98. | | 8861 b'p JYX-bW | |
| BA'9KGC'H'9FK-09'0077 ± 98. | | CB1) \$8811 @ \$ | |
| GNP | 7U[Y 7cXY. | BK; "BC" | F9J |
| 8 | '.)M | \$%) \$ | 6 |
| BC B'CHG7 5@98F5K-B: | | G7 5@%K 9% <H% Vg' | |

I B7 @GG±-98'DI 6@7