

Cabinet Bases

WCB Series



Why Choose the WCB series for your Enclosure?

Does your enclosure need a lift? Literally? Do you need a place to gather cable or have the enclosure in a more ergonomic position to work in? When it comes to pad mounting, working with cabling or power underneath, or if you simply need your enclosure to sit on top of the snow drifts instead of under it, look no further than DDB's extensive line of enclosure bases. All enclosure bases can be installed onto your enclosure by our professional in-house technicians guaranteeing a perfect fit every time, with an additional benefit of saving your time and money allowing you to focus on what is important. Contact our professional staff to assist you with your made-to-order solution.



Available Heights

3" Pedestal Base

(No Access Plate)

4" Pedestal Base

(No Access Plate)

6" Pedestal Base

(Access Plate F/R)

12" Pedestal Base

(Access Plate F/R)

24" Pedestal Base

(Access Plate F/R)

Available for WOD- DX, DD and DDX models



WCB-12, Shown in picture

Includes

1/2" Mounting Hardware

(Installing enclosure to base)

Features

15 Year Warranty

0.125" Aluminum Construction

Texture Cream Powder-Coat, Standard

Welded Corner Brackets Inside

Front and Rear Access Plate

Quick Shipping

Application Types

Telecommunications

Wireless/Broadband

Fiber Optics

Back Haul

Public Safety

Utility

Base Station

Military

Trailer-Based Communications

Wi-Fi

LTEE/4G/5G

2301 S. HWY 77 Pauls Valley, OK 73075

T: (405)-665-2876

sales@ddbunlimited.com www.ddbunlimited.com

Cabinet Bases

WCB Series

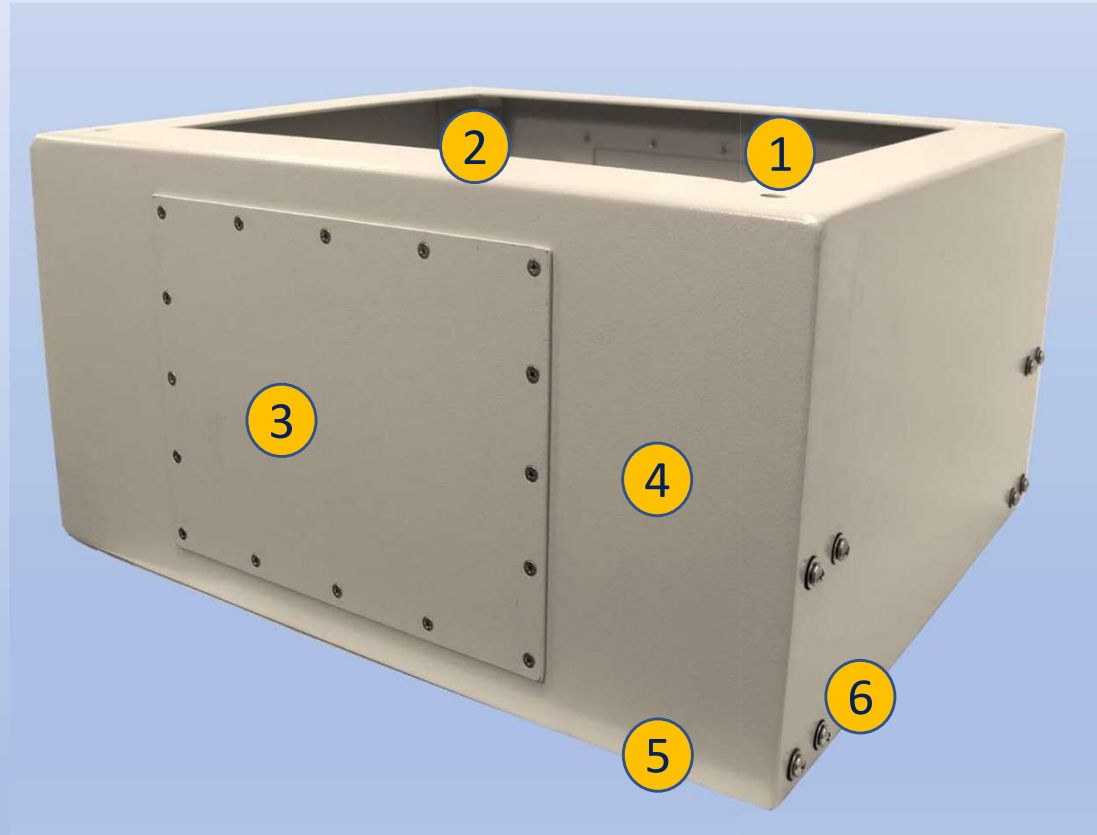

WCB-12, Shown in picture

Features

1. Threaded Mounting for ½" Bolts
2. Welded Corner Gussets for added support
3. Front and Rear Access Plate
(For Units That Are 6" Tall Or Larger)
4. Power Coat Cream Textured Finish
5. Four Bottom Mounting Holes For Concrete Pad Installation
(Not Shown In Picture See Drawings Below)
6. Mounting Option For Outside Mounting Feet

2301 S. HWY 77 Pauls Valley, OK 73075
T: (405)-665-2876

sales@ddbunlimited.com www.ddbunlimited.com

Scan this code for
Accessories

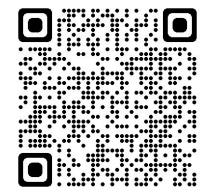

REVISIONS		
REV.	DESCRIPTION	DATE
A	WCB3-DX WEBSITE DRAWING	6/10/2020
B	UPDATED SHEET FORMAT	9/12/2024

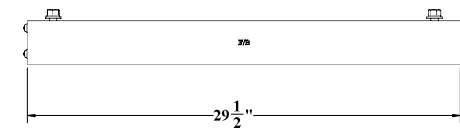
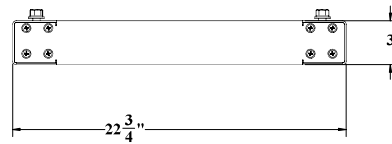
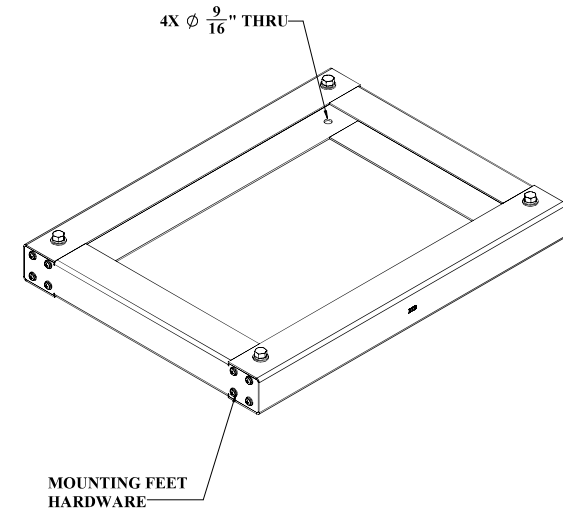
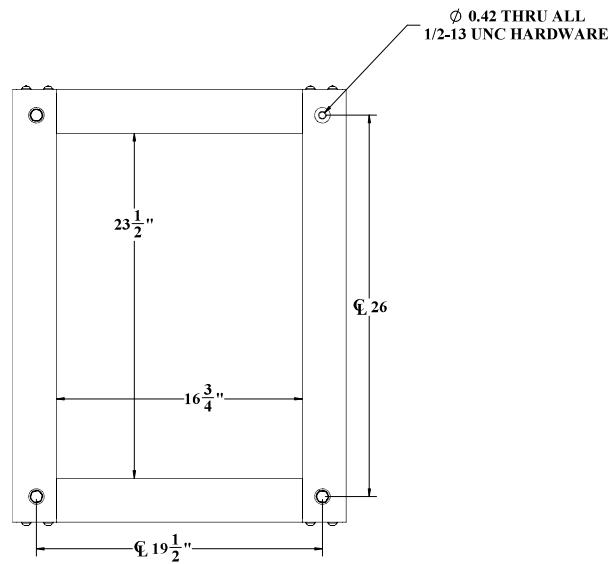

WCB3-DX

UNCLASSIFIED PUBLIC

DDB <i>Unlimited Inc.</i> CS34-DX-WOD			
REV.	Cage Code:	DWG. NO.:	REV.
D	38515	02344	B
SCALE: 1:4		WEIGHT: 10 lbs.	SHEET 1 OF 1

File Location: [DDB] (EPDM Vault)
 C:\DDB\DR Requests\C Customers\038 WEB DWG\Base\WCB3-DX\02344-WCB3-DX

DDB FORM: 7.1-2-REV.K 08/02/17

REVISIONS		
REV.	DESCRIPTION	DATE
A	WCB3-DDX WEBSITE DRAWING	6/10/2020
B	UPDATED SHEET FORMAT	9/12/2024

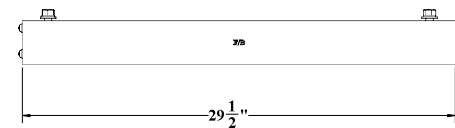
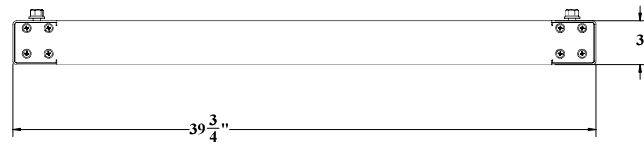
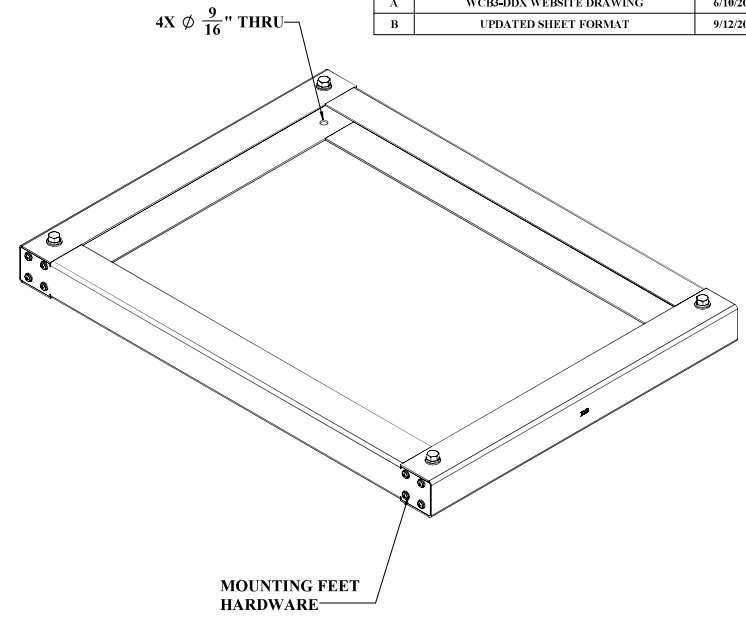
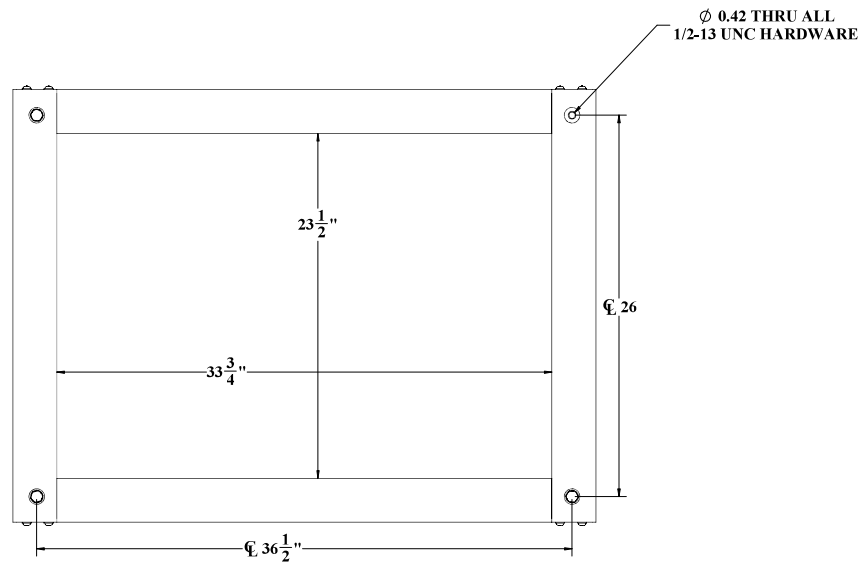

WCB3-DDX

UNCLASSIFIED PUBLIC

DDB UNLIMITED INC.	
C83-DDX-W03	
REV	Cage Code: DWG. NO.: REV
D	38515 02346 B
SCALE: 1:4 WEIGHT: 14 lbs. SHEET 1 OF 1	

File Location: (DDB) (EPDM Vault)
C:\DDB\DR Requests\Customer\DDX WEB DWG\Bases\WCB3-DDX\02346-WCB3-DDX\

DDB FORM: 7.1-2-REV.K 08/02/17

REVISIONS		
REV.	DESCRIPTION	DATE
A	CB4-DX-WOD WEBSITE	6/10/2020
B	UPDATED SHEET FORMAT	9/12/2024

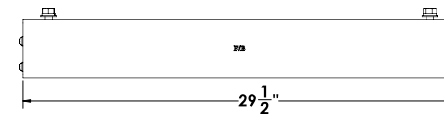
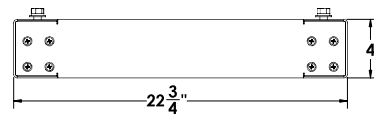
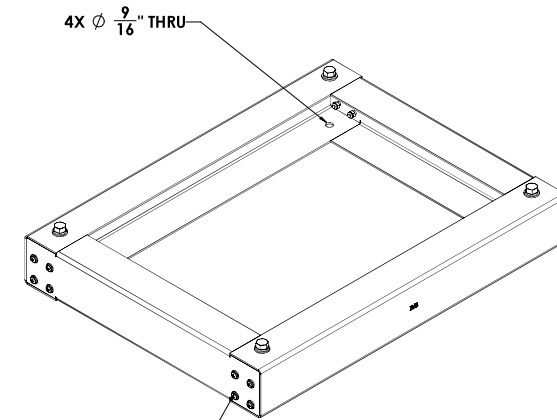
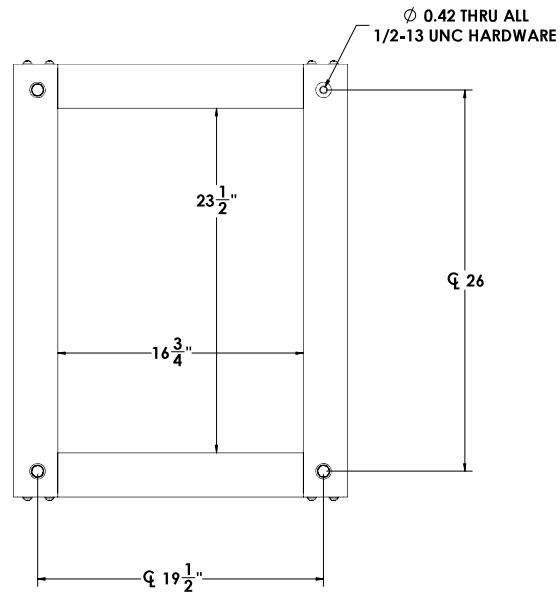

WOD-CB4-DX

DDBS COMPANY SPECIFIED: Manufacture all hardware: FINISH: POLYESTER POWDER COAT, R1100 COLOR: RAL 7035 ROUNDED CORNERS: R3.000 HOLE FINISH: POLISHED ALL DIMENSIONS IN INCHES		DDB Unlimited Inc. CB4-DX-WOD	
REV	Code Code:	DWG. NO.:	REV
D	28515	02347	B
SCALE: 1:4 WEIGHT: 12 lbs.		SHEET 1 OF 1	

PROPRIETARY AND CONFIDENTIAL
 THE INFORMATION CONTAINED IN THIS DRAWING IS THE SOLE PROPERTY OF DDB Unlimited, INC. ANY
 REPRODUCTION IN PART OR AS A WHOLE WITHOUT THE WRITTEN PERMISSION OF DDB Unlimited, INC. IS PROHIBITED.

File Location: [DDB] EPDM Vault:
 C:\DDB\DR Requests\Customer\308 WEB DWG\Base\WCB4DX\02347-WCB4-DX

DDB FORM: 7-1-2-REV.K 08/02/17

REVISIONS		
REV.	DESCRIPTION	DATE
A	WCB4-DD, WEBSITE DRAWING	6/10/2020
B	UPDATED SHEET FORMAT	9/12/2024

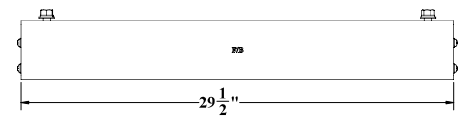
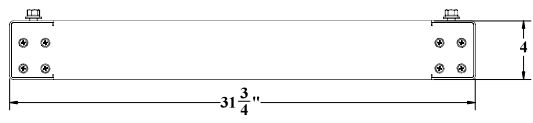
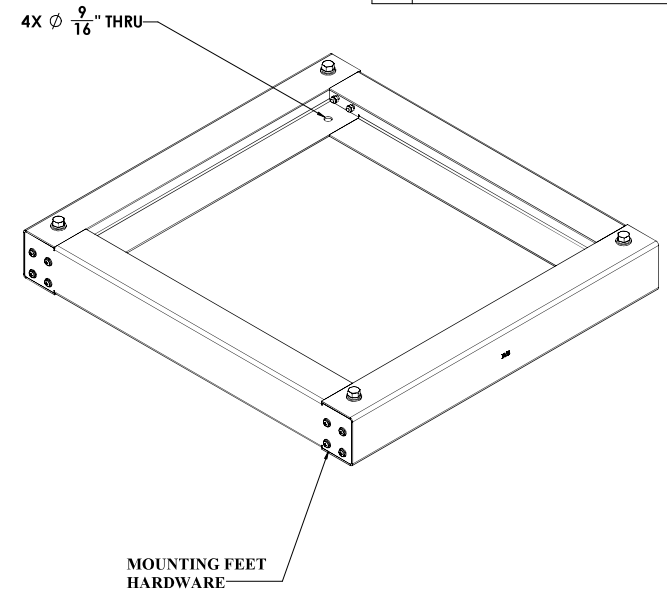
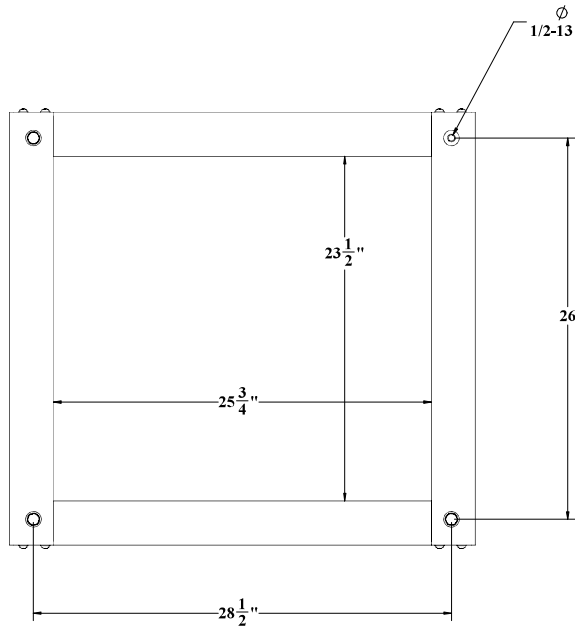

WCB4-DD

UNCLASSIFIED PUBLIC

SHEET CONTROLS SYSTEM: OPERATOR AND NOTES: JWC/LAR CUST/PROJ/REQM: 51 110 CUST/PROJ/REQM: 51 110 INT/PURCH/REQM: 51 110 INT/PURCH/REQM: 51 110 ALL RIGHTS RESERVED		DDB Unlimited Inc. C84-DD-W0D	
SHEET	Code Code:	DWG. NO.:	REV
D	38515	02348	B
SCALE: 1:4		WEIGHT: 14 lbs.	SHEET 1 OF 1

DDB FORM: 7-1-2 REV: 1 09/06/2024

REVISIONS		
REV.	DESCRIPTION	DATE
A	WCB4-DDX WEBSITE DRAWING	6/10/2020
B	UPDATED SHEET FORMAT	9/12/2024

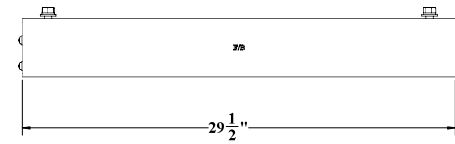
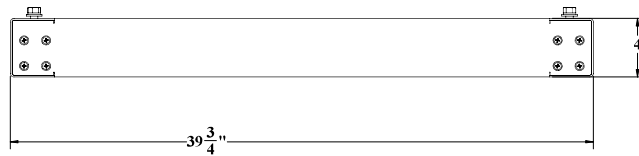
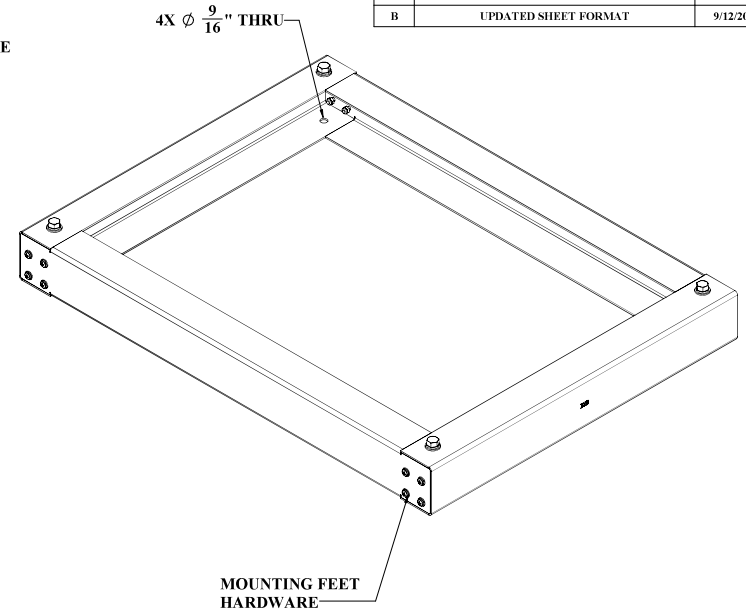
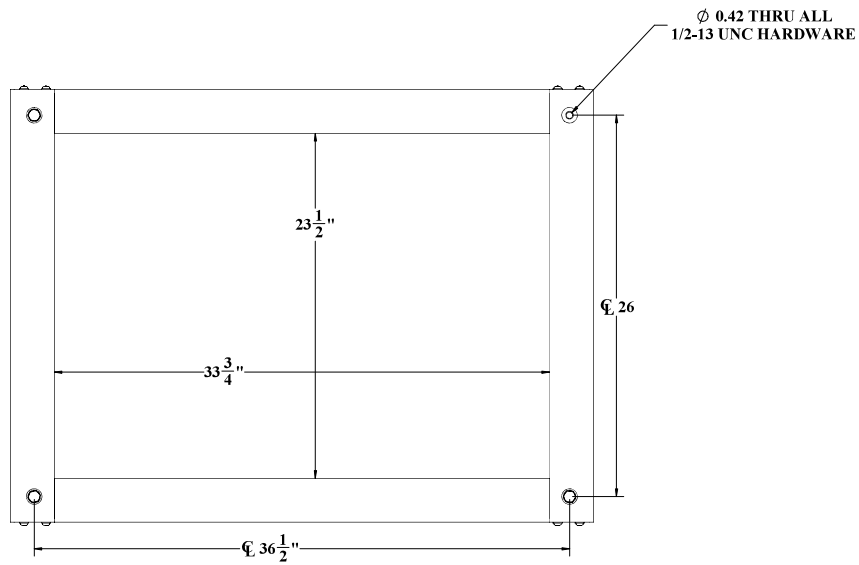

WCB4-DDX

UNCLASSIFIED PUBLIC

DDB Unlimited Inc. C84-DDX-WOD	
SHEET	Cage Code: 02349
D	REV B
SCALE: 1:4 WEIGHT: 14 lbs. SHEET 1 OF 1	

DO NOT SCALE DRAWING

File Location: [DDB] EPDM Vault
 C:\DDB\DR Requests\Customers\DDB WEB DWG\Bases\WCB4-DDX\02349-WCB4-DDX

DDB FORM: 7-1-2-REV:K 08/02/17

REVISIONS		
REV.	DESCRIPTION	DATE
A	WCB6-DX WEBSITE DRAWING	6/10/2020
B	UPDATED SHEET FORMAT	9/12/2024

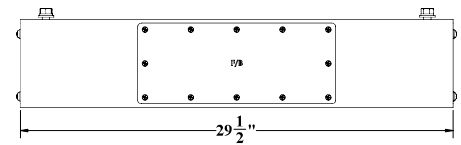
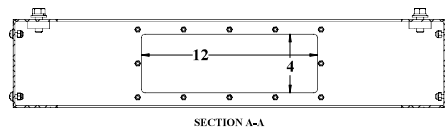
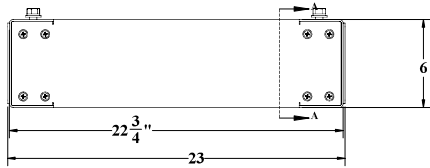
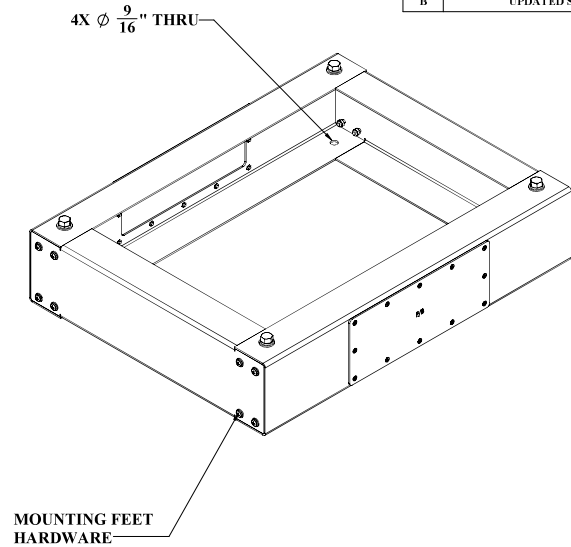
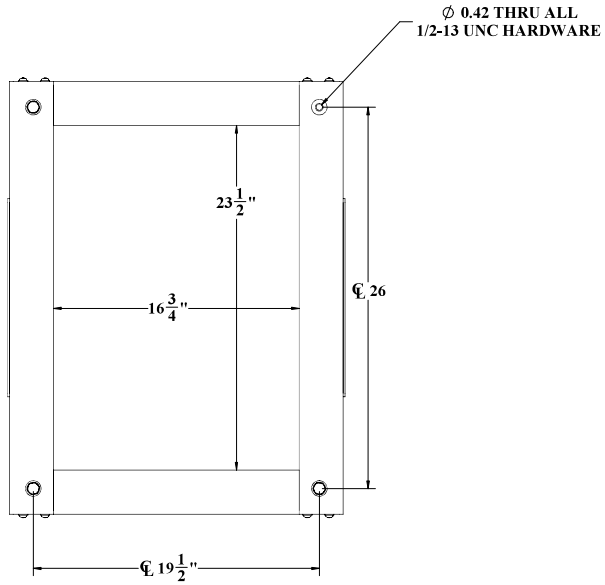

WCB6-DX

UNCLASSIFIED PUBLIC

DDB Unlimited Inc. CB6-DX-WOD	
SHEET: D SCALE: 1:4 DO NOT SCALE DRAWING	CODE: 02350 DWG. NO.: 02350 REV: B SHEET 1 OF 1

07/06/2024

REVISIONS		
REV.	DESCRIPTION	DATE
A	WCB12-DD WEBSITE DRAWING	6/11/2020
B	UPDATED WITH NEW FORMATS	9/11/2024

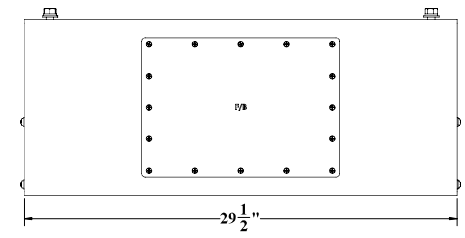
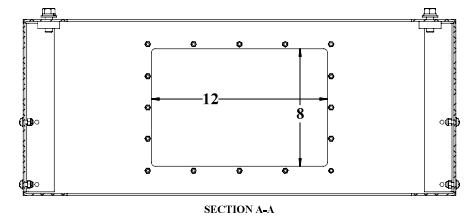
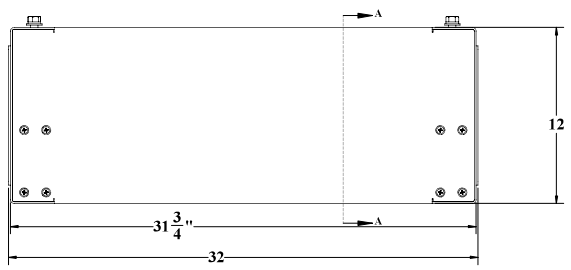
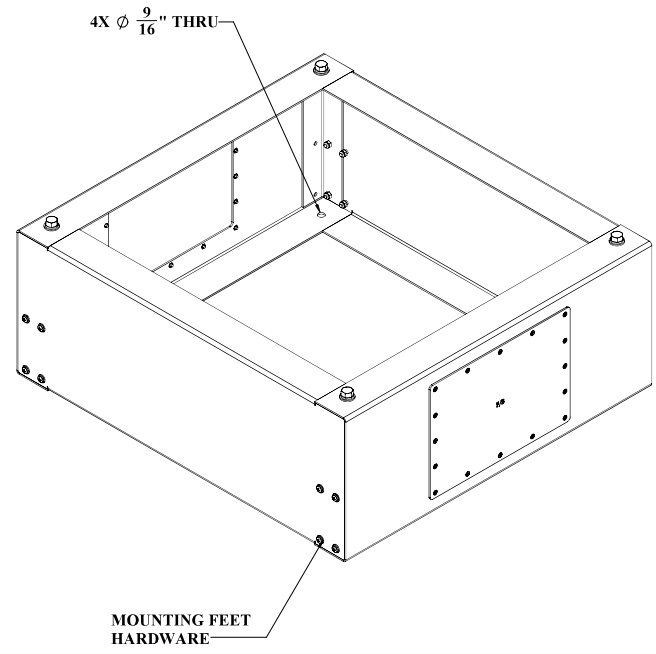
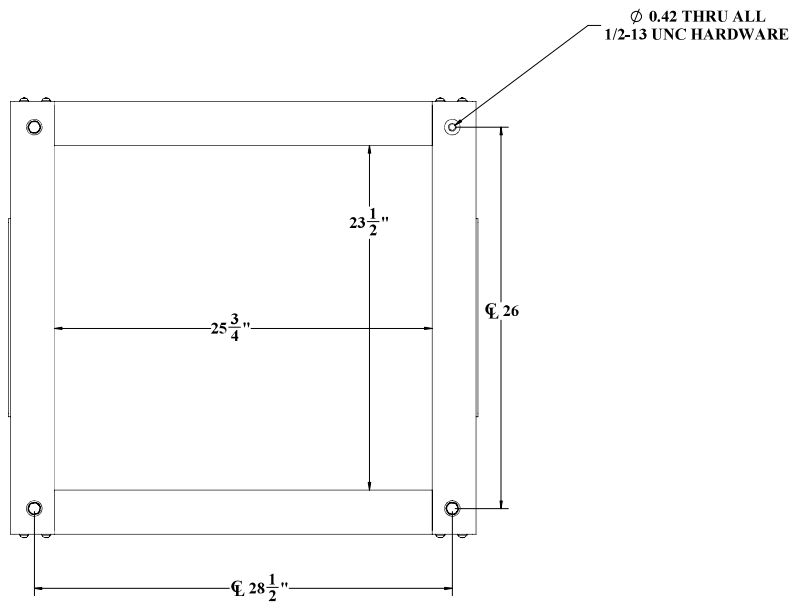

WCB12-DD

UNCLASSIFIED PUBLIC

DDB UNLIMITED SPECIFIED:		DDB Unlimited Inc.	
QUANTITIES SHOWN:		CB12-DD-WOD	
NO. OF UNITS	UNIT PRICE	TOTAL PRICE	REV.
1	02354	02354	0
SCALE: 1:4		WEIGHT: 27 lbs.	SHEET 1 OF 1

DDB FORM: 7-1-2-REV:K 09/06/2024

