

UL-50 WOD SERIES

WOD-30DDC-UL50



Why Choose the WOD-UL Series?

The WOD-30DDC-UL50 enclosure is the pinnacle of enclosures. With a fully welded chassis, heavy duty vulcanized gasketing and years of design and engineering behind it, you will find this will meet the most stringent requirements of the UL-50E Type 4 listing. Fully tested by a third party Nationally Recognized Testing Laboratory and listed to the UL-50E standard, you can trust that the WOD UL series will pass any test or inspection it faces. Designed with public safety requirements in mind, these units can be placed in mission critical locations where communication or sensitive gear needs to be protected regardless of the situation. As with the standard WOD series, the WOD-UL series comes with standard 3-point locking, front and rear access with integrated wind locks, top mounted solar shield, adjustable R-strut racking, reversible 19" or 23" EIA racking, Alumiflex construction and our unmatched 15-year warranty. Moreover, there is an extensive list of optional accessories including HVAC units, electrical panels, and cable entry solutions to name a few. No matter the application, DDB provides cutting-edge design, competitive pricing, benchmark lead times, and guaranteed delivery. Whether you require a custom enclosure or something from our substantial stock, our professional staff is here to help you today.



Features

15 Year Warranty

0.125" Aluminum Construction

3-Point Locking System

Heavy Duty Out-Door Construction

Front and Rear Access

Stainless Steel External Hardware/Hinge

Cream Powder-Coat, Standard

Wind Locks

Quick Shipping

Weight and Dimensions

Approximate Exterior Enclosure Dimensions:

32"H x 33"W x 39"D

Shipping Dimensions:

48"L x 42"W x 40"H- Palletized

Approximate Shipping Weight:

175 lbs.

Application Types

Telecommunications

Wireless/Broadband

Fiber Optics

Back Haul

Public Safety

DAS

Utility

Base Station

Military

Trailer-Based Communications

Wi-Fi

LTEE/4G/5G

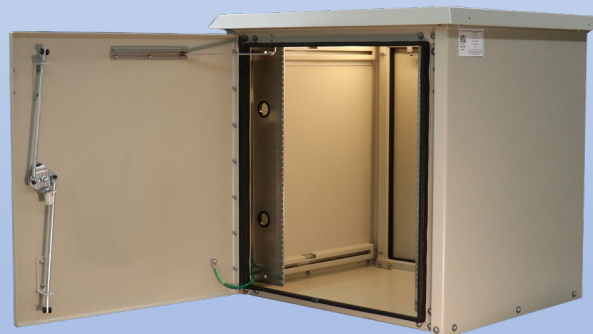

Environmental & Safety Ratings:

- ✓ ETL environmentally listed to UL 50/50E, IP 66, Type 4
- ✓ ETL listed; Safety Requirements, UL 62368-1:2019 Ed.3, CSA C22.2

2301 S. HWY 77 Pauls Valley, OK 73075

T: (405)-665-2876

sales@ddbunlimited.com www.ddbunlimited.com

UL-50 WOD SERIES

WOD-30DDC-UL50

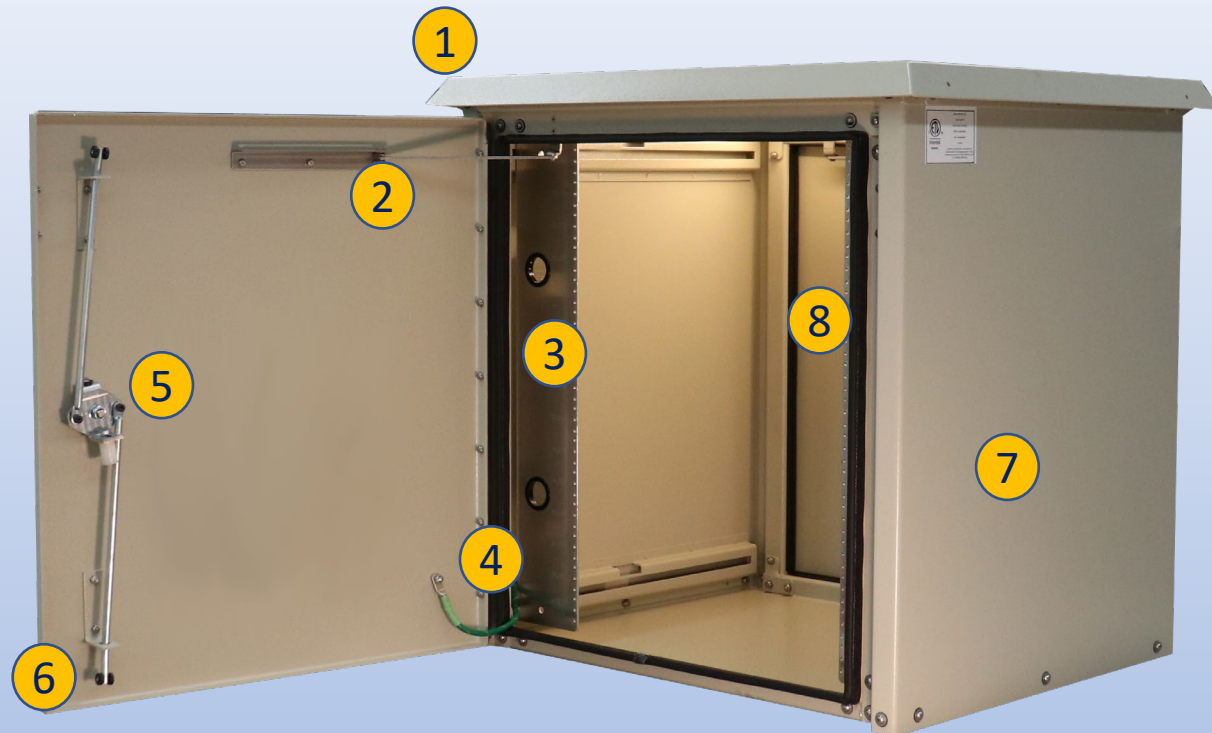

Features

6

1. Alumishield
2. Wind Locks
3. 19" and 23" Adjustable Racking Rails
4. Stainless Steel Door Hinge
5. 3-Point Locking System
6. Heavy Duty 0.160" Doors
7. Powder-Coat Cream
8. Rear Door Access

2301 S. HWY 77 Pauls Valley, OK 73075

T: (405)-665-2876

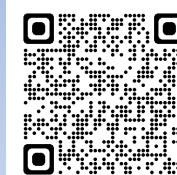
sales@ddbunlimited.com www.ddbunlimited.comScan this code for
Climate ControlScan this code for
Accessories

REVISIONS		
REV.	DESCRIPTION	DATE
A	CREATED DRAWING PER DR-02053	7/16/2019

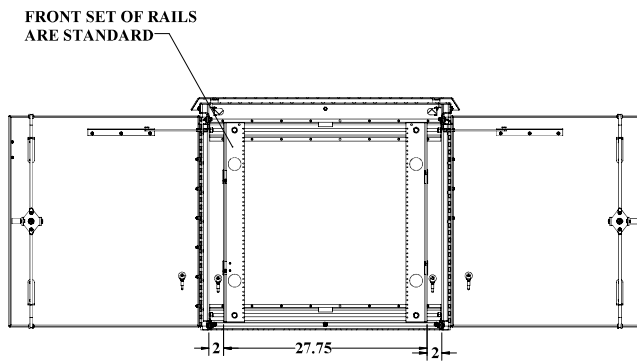
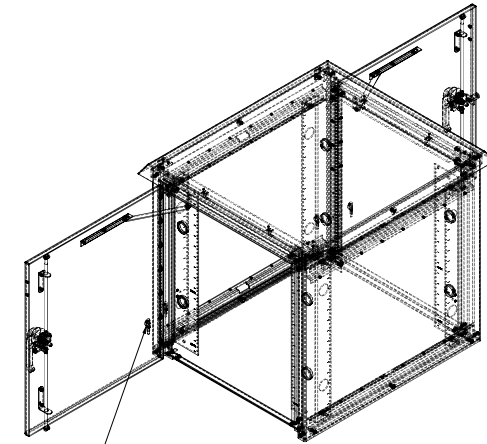
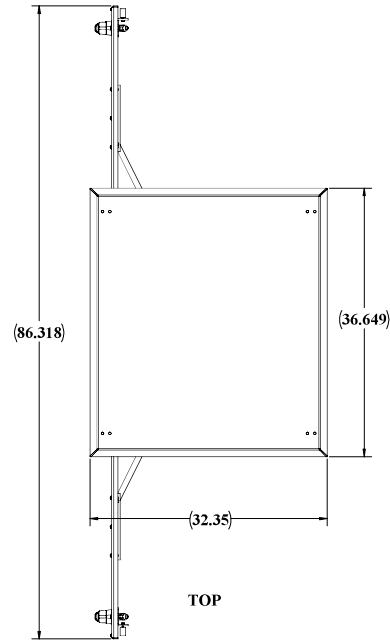

SECTION A-A
SCALE 1:8

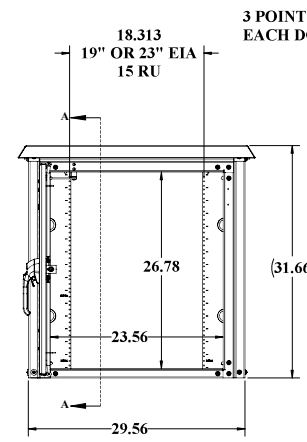

3 POINT LOCKING
EACH DOOR

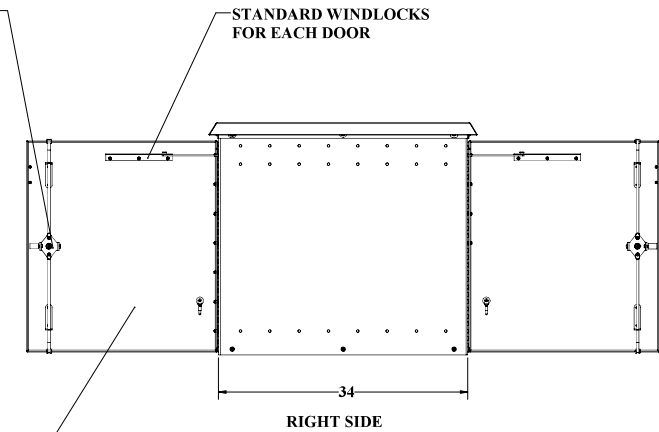

NO VENTS OR LOUVERS

WELDED ENCLOSURE

UNLESS OTHERWISE SPECIFIED:			
DIMENSIONS ARE IN INCHES			
WELDING	AS PER SPECIFICATION	AS SHOWN	
FINISH	AS PER SPECIFICATION	AS SHOWN	
PAINT	AS PER SPECIFICATION	AS SHOWN	
MATERIAL SPECIFICATIONS: ALUMINUM			
FINISH: POLYURETHANE EPOXY POWDER COAT			
DO NOT SCALE DRAWING			
DDB Unlimited Inc.		WCD-300D-UL50E	
W.O.D. 30" H. 18.5" W. 15.5" D. 15.5" W.O.D. 300D-UL50E			
SHEET	Code Code:	DWG. NO.:	REV
D	28515	02053	A
SCALE: 1:12		WEIGHT: 127 lbs.	SHEET 1 OF 3

UNCLASSIFIED PUBLIC

WEB DRAWING (NOT FOR FABRICATION)

$\phi \frac{9}{16}$ "
ETCHNGS

$\phi 26$
FLOOR ETCHNGS

27.75
RAIL FACE
TO RAIL FACE

$\phi 28 \frac{1}{2}$ "
FLOOR ETCHNGS

$38 \frac{3}{4}$ "

29.75

$27 \frac{3}{4}$ "
R-STRUT
TO R-STRUT

(2.27)

TOP VIEW
NO CEILING OR ALUMASHIELD SHOWN

WEB DRAWING (NOT FOR FABRICATION)

UNLESS OTHERWISE SPECIFIED:			
DIMENSIONS ARE IN INCHES			
FINISH	FINISH	FINISH	FINISH
OUTSIDE SURFACE	INSIDE SURFACE	DRILL FLUTE SURFACE	DRILL FLUTE SURFACE
AS SHOWN	AS SHOWN	AS SHOWN	AS SHOWN
ALL DIMENSIONS ARE TO FACE UNLESS OTHERWISE SPECIFIED			
MATERIAL SPECIFICATION: ALUMINUM 6061-T6			
PAINT: PRIMER/PAINT: ANTI-CORROSION/PAINT: POLYURETHANE			
DO NOT SCALE DRAWING			
DDB Unlimited Inc.		JOB: CLOSED - DD UL-500A-UL-500-CLOSED	
REV	Code Code:	DWG. NO.:	REV
D	28515	02053	A
SCALE: 1:12		WEIGHT: 13 lbs.	SHEET 2 OF 3

CUSTOMER CONFIDENTIAL

DDB FORM: 7.1.2 REV: A 08/02/17

WEB DRAWING (NOT FOR FABRICATION)

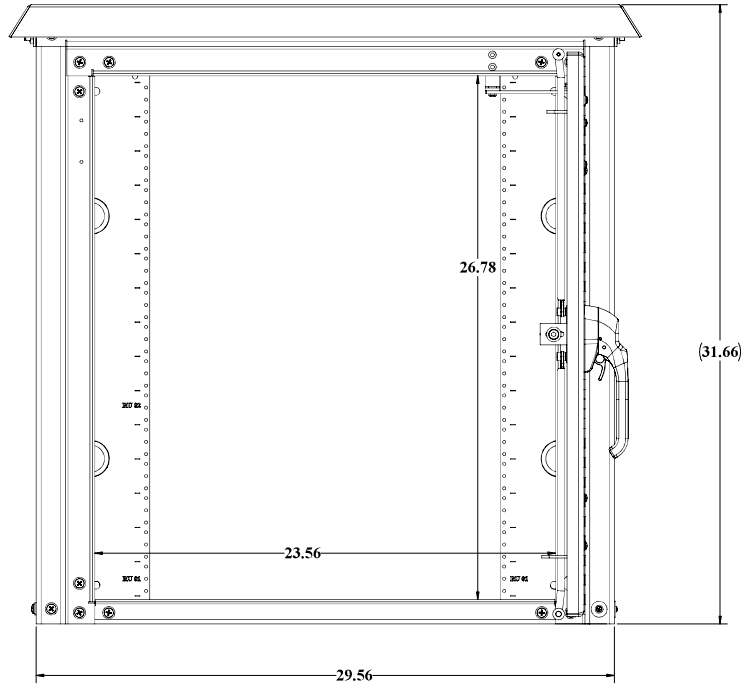

BACK VIEW
GASKET NOT SHOWN

CUSTOMER CONFIDENTIAL

WEB DRAWING (NOT FOR FABRICATION)

UNLESS OTHERWISE SPECIFIED:			
DIMENSIONS ARE IN INCHES			
WOOD-300D-UL50E			
FINISH	W/O.D. W/1/4" DR-L150W/O.D.-300D-UL50E		
RE	Code Code:	DWG. NO.:	REV
D	28515	02053	A
MATERIAL SPECIFIED BY ALTA FORMS			
PAINT: BROWN/BLACK; BLDG: UNFINISHED			
DO NOT SCALE DRAWING		SCALE: 1:12	WEIGHT: 127 lbs
2		SHEET 3 OF 3	

DDB Unlimited Inc.

W/O.D. W/1/4" DR-L150W/O.D.-300D-UL50E

Code Code: DWG. NO. REV

D 28515 02053 A

SCALE: 1:12 WEIGHT: 127 lbs SHEET 3 OF 3

DDB FORM: 7.1.2 REV: AK 08/02/17